

INSTRUCTION MANUAL

J-SERIES



By *Folke Pålsson, Jørgen Bækmark*
& *Poul M. Volther*

HAY

INTRODUCTION

Designed to recreate the classic FDB furniture collection, the J-Series offers a functional design born out of industrial development. FDB created a strong furniture concept in 1933, and under Børge Mogensen's leadership as design director from 1942, the FDB furniture linked industrial production closely with architectural furniture design. The primary focus was not on detailing, but on making well-designed furniture accessible to the general population. The industrial approach eliminated the need for special components and all chairs featured identical legs. FDB revolutionised the industry as a precursor of many of the design icons that Denmark is acknowledged for today around the world.

CARE AND MAINTENANCE

CAUTION

With a little care you can prolong the life of your furniture. Follow the instructions for the materials of your specific product to make sure that it stays in the best shape for as long as possible.

The information below is only intended as a general guideline. For more information on how to remove specific stains, please enquire where you bought the furniture.

- Always remove stains quickly before they can do any permanent damage to the furniture.
- Avoid placing the furniture in direct sunlight or near a strong heat source to reduce changes. As wood is a natural material, it will change in colour and will patinate over time.
- When you move your furniture, make sure you lift it rather than pulling or pushing it to avoid damaging the floor, legs and mountings.
- Tighten up the screws after one to two months' use and whenever required.
- Avoid improper use such as sitting on the back or armrests, tilting the seats on their back legs, putting your feet on the furniture or standing on it.
- Be careful not to scratch or damage the surface with sharp objects.
- Check the status of the gliders frequently and if worn down, contact your local retailer to buy replacements. The durability of the gliders will depend on the surface the chair is placed on.

CARE AND MAINTENANCE

STAINED BEECH

- Wipe with a clean cloth wrung in water or in a solution of water and a neutral detergent. Remove soap residue immediately using a clean, dry cloth.
- If the surface is scratched or appears matt, use a care product especially suited to stained wood.
- Avoid using detergents containing silicone, as they seal the stain in and make subsequent repairs more difficult.
- Avoid using scouring cream or scouring pads, as they may scratch the surface.

NATURE BEECH

- Wipe with a clean cloth wrung in water or in a solution of water and a neutral detergent or soap flakes. Remove soap residue immediately using a clean, dry cloth.
- To remove stains, clean and scrub using a thick solution of soap flakes that should not stay on the wood for more than 2 minutes. Then remove the remaining soap residue using a damp cloth.
- If the grain of the wood rises after cleaning, gently sand down the wood using fine-grit sandpaper (No. 220), always sanding in the direction of the grain.
- If the surface is scratched or appears matt, use a care product specifically suited to soaped wood.

J77

By FOLKE PÅLSSON

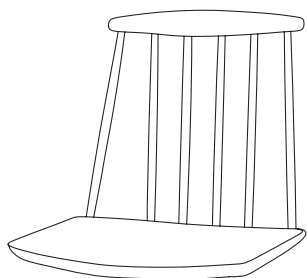

Seat (A) x 1

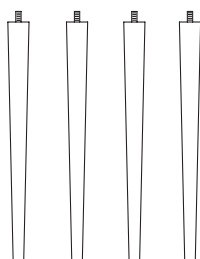

Leg (B) x 4



Spacer (C) x 2

MOUNTING THE LEGS

Mount the legs (B) using the same angle as the bushing, and tighten them firmly.

Use a spacer (C) between the seat and the leg in case the chair tilts.

(See >NOTE< on last page).

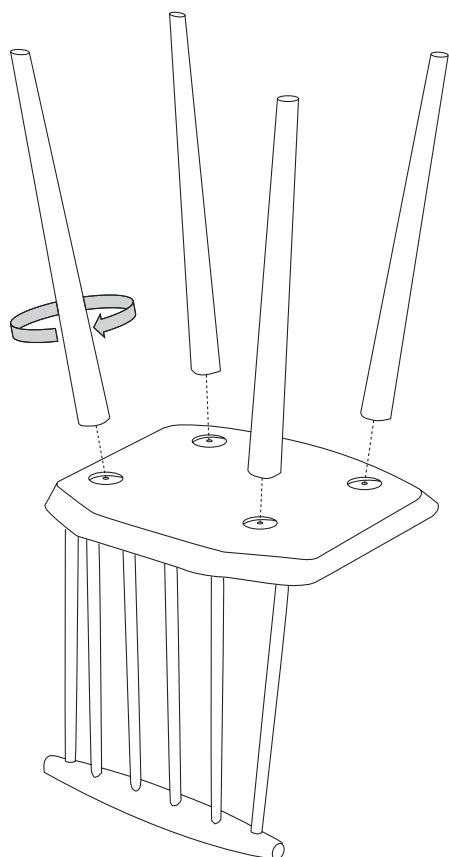

Remember to retighten the legs regularly.

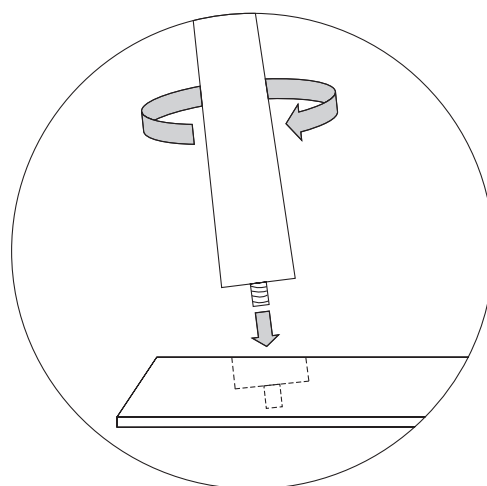

By JØRGEN BÆKMARK

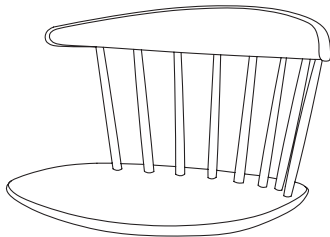

Seat (A) x 1

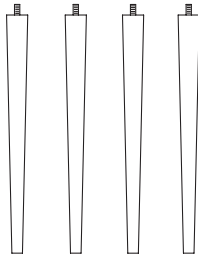

Leg (B) x 4



Spacer (C) x 2

MOUNTING THE LEGS

Mount the legs (B) using the same angle as the bushing, and tighten them firmly.

Use a spacer (C) between the seat and the leg in case the chair tilts.

(See >NOTE< on last page).

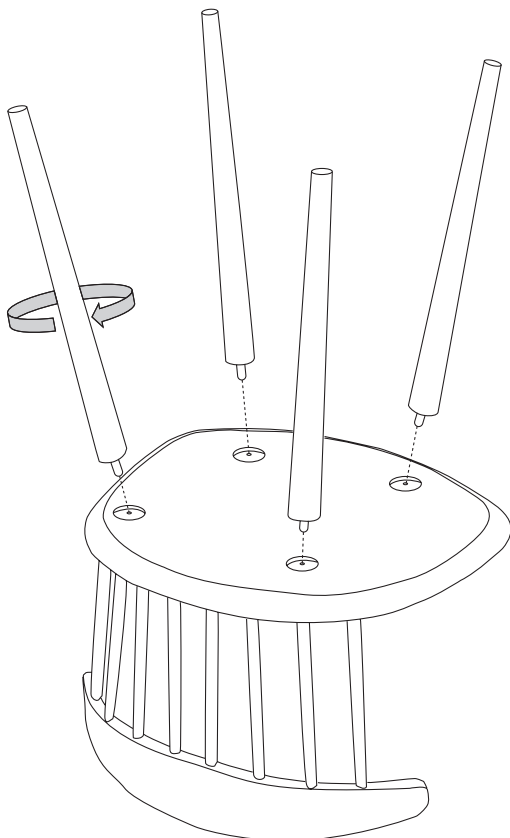

Remember to retighten the legs regularly.

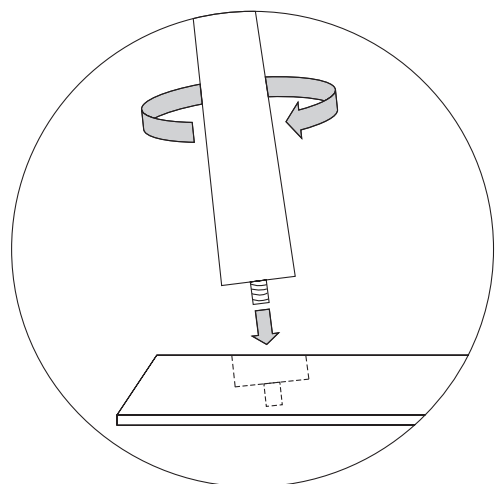

J110

By POUL M. VOLTHER

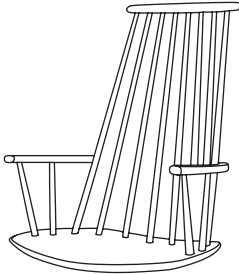

Seat (A) x 1



Leg 40cm
(B) x 2



Leg 43cm
(C) x 2



Spacer (D) x 2

MOUNTING THE LEGS

Mount the shortest legs (B) at the rear of the seat (A), and the longest legs (C) at the front of the seat (A), and tighten them firmly. Make sure to mount the legs using the same angle as the bushing. Use a spacer (C) between the seat and the leg in case the chair tilts.

(See >NOTE< on last page).

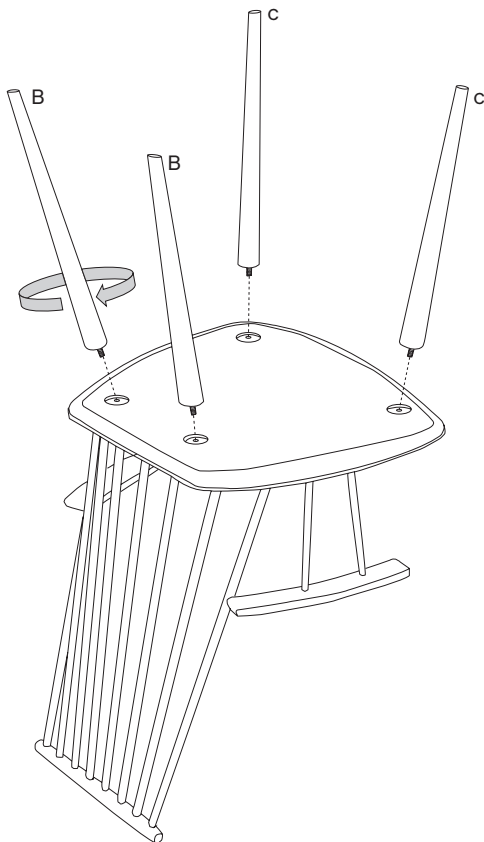

Remember to retighten the legs regularly.

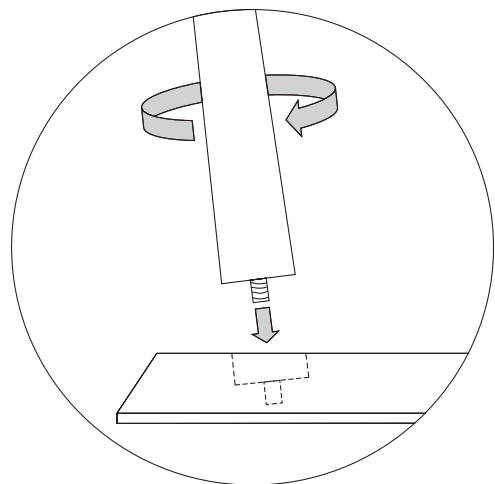

NOTE

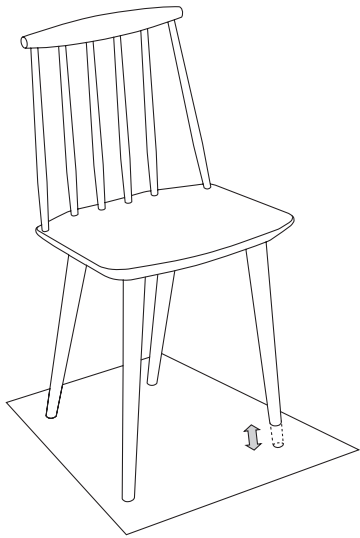

Spacer (C) x 2

CHAIR TILT

In case the chair tilts, use one or two spacers (C) between the seat (A) and the leg (B).

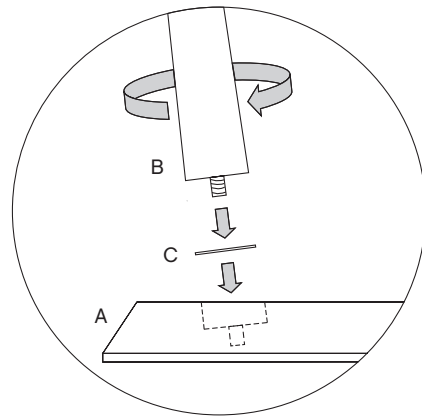
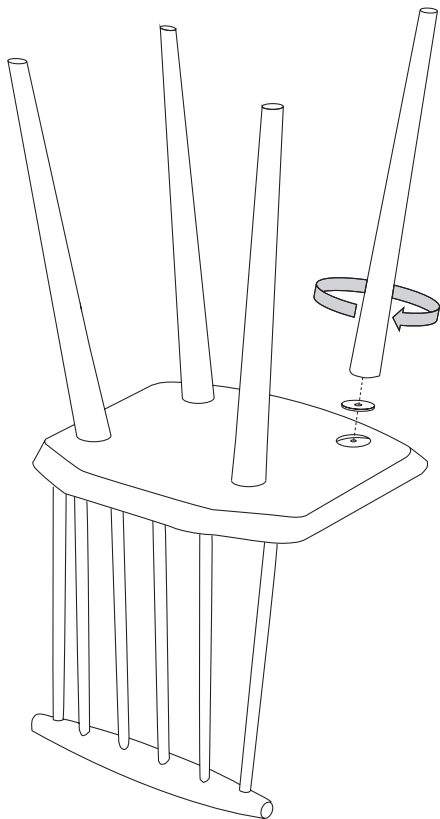

One or two spacers needed.

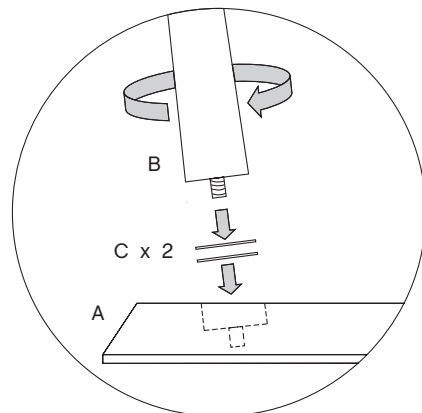

Havnen 1 8700 Horsens Denmark
+45 4282 0282 / hay@hay.dk

HAY

ITEM NO. 706347

