



MØBLER

- A PHILOSOPHY -

*“You ought to feel at home
in a piece of furniture”*

Quote: Thomas Alken

Dear Customer

FDB Møbler was founded out of a desire to create furniture that makes room for people – a philosophy which has been shaped in oak and beech and woven into seats since 1942. New generations of designers have joined the team since then, but the fundamental mission remains the same: To produce beautiful, functional pieces of furniture made to high standards of craftsmanship that make room for everyday life in living rooms, kitchens and children’s bedrooms. And which can withstand wear and tear, year in and year out. FDB Møbler wrote itself into the annals of Danish design history long ago with classics that

have been passed down for generations. So even if your furniture is brand new, it is already an heirloom, because it is imbued with all the values that we were born with, and which are still honoured to this day when we produce our classics, relaunch furniture from our design archives, or introduce brand-new designs. We hope you will be happy with your new purchase, and that it will enhance your quality of life, as this has been the intention ever since our first pieces of furniture emerged from the drawing board.

• M1 • Sammen – Dining chair

Designer Thomas Alken

PRODUCT INFORMATION

FDB Møbler’s dining chair is designed for sunny lunches and long summer evenings in the garden. It is a chair designed according to the traditions shared by FDB Møbler, but reinterpreted as a piece of garden furniture. The natural, oiled teak creates the same feel as the classic dining chairs that we use inside. However, the material and shape are, of course, adapted for outdoor use. The chair beautifully matches the two dining tables in the series. The chair exudes an air of quality and style not normally associated with garden furniture.

Thomas Alken (b. 1970) graduated as a furniture and industrial designer from Design School Kolding in 1997. He has been involved in a wide range of design projects, from luxury furniture and ketchup bottles to a lounge at Copenhagen Airport, because it is the user situation that fascinates him. In his view, furniture must always be seen in a larger context. And with the ‘Sammen’ (Together) series, he has made sure that the furniture harmonises with the traditions of FDB Møbler as well as Danish gardens.

CARE INSTRUCTIONS

We always recommend that garden furniture is carefully looked after and maintained. In Denmark, humidity levels and large temperature fluctuations can cause wood to crack and warp. This means that mould, for example, is more likely to attack the wood. So, there are many good reasons why you should maintain your wooden garden furniture. The wood will retain its beautiful colour rather than becoming grey and dreary to look at. The garden furniture will be protected against degradation from the weather, wind and sun, and will therefore last longer. With proper treatment, teak garden furniture can last for many years. Teak contains a lot of natural oils and minerals, so teak furniture can to some

extent be left untreated. Over time, the wood will acquire a silver-grey surface, as the rain and sun wash and dry out the top oil layer which is naturally found in the wood. However, to keep the wood healthy, it is a good idea to oil your furniture at least once a year. If you wish to retain the silver-grey finish, use natural oil without colour pigments.

Wooden garden furniture should be washed often to remove dust and dirt to prevent blotching etc. on the surface. If you want to retain the beautiful golden hue of new teak, it should be treated with oil one to three times a year like all other wood types, and with a teak oil containing colour pigments. Before bringing wooden garden furniture inside for the winter, it is important to clean it thoroughly to prevent rot and mould from developing. Retighten the bolts and screws if necessary. It is a good idea to end the season by oiling or painting the furniture. Wood is a living material, and therefore benefits from being stored in a shed, so it is not exposed to moisture during the winter. Wooden garden furniture should not be in direct contact with the ground, as the legs will absorb moisture. If necessary, place tiles under the legs, or make sure to wrap the tarpaulin under the legs of both chairs and tables. Wooden garden furniture does not benefit from being stored in a warm room during the winter, as the wood can dry out completely. This can cause large cracks, and the wood may shrink. When the time comes to take your garden furniture back out into the garden again, it is important that you tighten the screws, bolts and brackets which might have become loose during the winter.

Lubricate all moving parts with a neutral oil (for example sewing machine oil). Wash the garden furniture thoroughly. If the furniture was oiled or painted before being put away for the winter, it should now be ready for use. If not, it is a good idea to do so before starting to use the furniture again.



FDB Møbler is manufactured using only FSC-certified wood. FSC certification ensures that no more trees are felled than the forest can reproduce. At the same time, the FSC label guarantees that forest animals and plants are protected, and that the forest workers receive training, safety equipment and a reasonable pay. When you, the consumer, choose FSC, you are helping to protect the natural environment and ensure proper social conditions in the forests where the wood is sourced. In choosing products made with FSC wood, you are supporting forest owners who have chosen to manage their forests in a way that respects the people who work there and the fauna for which the forest is their habitat. For further information, visit www.fsc.dk.



MØBLER

- A PHILOSOPHY -

*“You ought to feel at home
in a piece of furniture”*

Quote: Thomas Alken

Cleaning

Garden furniture should be cleaned to remove any algae and dirt. It is important to make sure that the furniture is completely clean before it is oiled. Remove dirt, old oil, mould and algae using a stiff brush and plenty of water. Perhaps add a little wood cleaner to the water. However, remember to rinse the furniture thoroughly after washing. Different types of wood cleaner are available, for example wood cleaner for teak, which cleans the wood without removing the natural oils in the wood. Buy the products that are the most suitable for the garden furniture. If the wood is very worn or damaged, it can be deep-cleaned by means of a two-stage cleaning process: First, wash the wood thoroughly, and then neutralise the cleaning to reveal the wood's natural glow and appearance. It is important that the garden furniture dries properly before proceeding to the next step.

Sanding

Often the wood will rise after being soaked with water and cleaner, so all the surfaces need to be sanded. First, use a coarse sandpaper (e.g. 100-120 grit), and then sand with a fine sandpaper (e.g. 200-300 grit). It is important that you always sand with the grain, i.e. lengthwise. Both oiled and painted garden furniture must be sanded. This is necessary to create a fine, smooth surface before treating with oil, or to ensure that the paint adheres to the wood. If the furniture has marks or discolorations which have not been properly treated, or if the furniture has not been stored correctly, such marks and discolorations can often be removed by sanding. Any sanding dust should be removed before the next step.

Oiling/painting

Oiling/painting should be done in a relatively warm place (10-25°C), but not inside so you avoid inhaling oil fumes. Protect the wood with fungicidal oil or paint that will prevent mould and algae growth. If the garden furniture is going to be painted, the best result is achieved by first applying a layer of primer, which should always be allowed to dry until the following day. If the garden furniture is going to be oiled, it is a good idea to use a pigmented oil, which protects the wood against the sun's harmful UV rays. Evenly apply the wood oil or paint using a brush. Take care to saturate the end grain with oil/paint. If necessary, wipe off any small pools of surplus oil on horizontal surfaces with a cloth. These form when the wood is saturated with oil. The garden furniture must have at least two coats of oil/paint to ensure a satisfactory finish. Once the garden furniture has been treated, it should be left for a few days until the oil/paint is completely dry and can withstand the rain, sun and wind outside. The better the quality of the oil/paint, the better the result. Oil or paint can be purchased from paint shops, builders' merchants and DIY stores. Here, it is also possible to obtain professional advice on which type of oil/paint to use.

Please note!

IT IS IMPORTANT THAT GARDEN FURNITURE STANDS ON A FLAT SURFACE SO THAT ALL THE LEGS ARE IN CONTACT WITH THE GROUND.



FDB Møbler is manufactured using only FSC-certified wood. FSC certification ensures that no more trees are felled than the forest can reproduce. At the same time, the FSC label guarantees that forest animals and plants are protected, and that the forest workers receive training, safety equipment and a reasonable pay. When you, the consumer, choose FSC, you are helping to protect the natural environment and ensure proper social conditions in the forests where the wood is sourced. In choosing products made with FSC wood, you are supporting forest owners who have chosen to manage their forests in a way that respects the people who work there and the fauna for which the forest is their habitat. For further information, visit www.fsc.dk.



MØBLER

- A PHILOSOPHY -

*“You ought to feel at home
in a piece of furniture”*

Quote: Thomas Alken

Dear Customer

FDB Møbler was founded out of a desire to create furniture that makes room for people – a philosophy which has been shaped in oak and beech and woven into seats since 1942. New generations of designers have joined the team since then, but the fundamental mission remains the same: To produce beautiful, functional pieces of furniture made to high standards of craftsmanship that make room for everyday life in living rooms, kitchens and children’s bedrooms. And which can withstand wear and tear, year in and year out. FDB Møbler wrote itself into the annals of Danish design history long ago with classics that

have been passed down for generations. So even if your furniture is brand new, it is already an heirloom, because it is imbued with all the values that we were born with, and which are still honoured to this day when we produce our classics, relaunch furniture from our design archives, or introduce brand-new designs. We hope you will be happy with your new purchase, and that it will enhance your quality of life, as this has been the intention ever since our first pieces of furniture emerged from the drawing board.

• M2 • Sammen - Dining table

Designer Thomas Alken

PRODUCT INFORMATION

This large garden table is perfect for spending time and socialising outdoors. Here, we come together for long lunches and cheerful bonhomie during the long summer evenings. FDB Møbler has produced countless dining tables over the years, and C201b should be seen as part of this tradition – just for outdoor use. The table has naturally rounded ends, with the ingenious detail that the ends can be detached, and then two tables can be joined using a table leaf.

Thomas Alken (b. 1970) graduated as a furniture and industrial designer from Design School Kolding in 1997. He has been involved in a wide range of design projects, from luxury furniture and ketchup bottles to a lounge at Copenhagen Airport, because it is the user situation that fascinates him. In his view, furniture must always be seen in a larger context. And with the ‘Sammen’ (Together) series, he has made sure that the furniture harmonises with the traditions of FDB Møbler as well as Danish gardens.

CARE INSTRUCTIONS

We always recommend that garden furniture is carefully looked after and maintained. In Denmark, humidity levels and large temperature fluctuations can cause wood to crack and warp. This means that mould, for example, is more likely to attack the wood. So, there are many good reasons why you should maintain your wooden garden furniture. The wood will retain its beautiful colour rather than becoming grey and dreary to look at. The garden furniture will be protected against degradation from the weather, wind and sun, and will therefore last longer. With proper treatment, teak garden furniture can last for many years. Teak contains a lot of natural oils and minerals, so teak furniture can to some extent be left untreated. Over time, the wood will acquire a silver-grey sur

face, as the rain and sun wash and dry out the top oil layer which is naturally found in the wood. However, to keep the wood healthy, it is a good idea to oil your furniture at least once a year. If you wish to retain the silver-grey finish, use natural oil without colour pigments.

Wooden garden furniture should be washed often to remove dust and dirt to prevent blotching etc. on the surface. If you want to retain the beautiful golden hue of new teak, it should be treated with oil one to three times a year like all other wood types, and with a teak oil containing colour pigments. Before bringing wooden garden furniture inside for the winter, it is important to clean it thoroughly to prevent rot and mould from developing. Retighten the bolts and screws if necessary. It is a good idea to end the season by oiling or painting the furniture. Wood is a living material, and therefore benefits from being stored in a shed, so it is not exposed to moisture during the winter. Wooden garden furniture should not be in direct contact with the ground, as the legs will absorb moisture. If necessary, place tiles under the legs, or make sure to wrap the tarpaulin under the legs of both chairs and tables. Wooden garden furniture does not benefit from being stored in a warm room during the winter, as the wood can dry out completely. This can cause large cracks, and the wood may shrink. When the time comes to take your garden furniture back out into the garden again, it is important that you tighten the screws, bolts and brackets which might have become loose during the winter.

Lubricate all moving parts with a neutral oil (for example sewing machine oil). Wash the garden furniture thoroughly. If the furniture was oiled or painted before being put away for the winter, it should now be ready for use. If not, it is a good idea to do so before starting to use the furniture again.



FDB Møbler is manufactured using only FSC-certified wood. FSC certification ensures that no more trees are felled than the forest can reproduce. At the same time, the FSC label guarantees that forest animals and plants are protected, and that the forest workers receive training, safety equipment and a reasonable pay. When you, the consumer, choose FSC, you are helping to protect the natural environment and ensure proper social conditions in the forests where the wood is sourced. In choosing products made with FSC wood, you are supporting forest owners who have chosen to manage their forests in a way that respects the people who work there and the fauna for which the forest is their habitat. For further information, visit www.fsc.dk.



MØBLER

- A PHILOSOPHY -

*“You ought to feel at home
in a piece of furniture”*

Quote: Thomas Alken

Cleaning

Garden furniture should be cleaned to remove any algae and dirt. It is important to make sure that the furniture is completely clean before it is oiled. Remove dirt, old oil, mould and algae using a stiff brush and plenty of water. Perhaps add a little wood cleaner to the water. However, remember to rinse the furniture thoroughly after washing. Different types of wood cleaner are available, for example wood cleaner for teak, which cleans the wood without removing the natural oils in the wood. Buy the products that are the most suitable for the garden furniture. If the wood is very worn or damaged, it can be deep-cleaned by means of a two-stage cleaning process: First, wash the wood thoroughly, and then neutralise the cleaning to reveal the wood's natural glow and appearance. It is important that the garden furniture dries properly before proceeding to the next step.

Sanding

Often the wood will rise after being soaked with water and cleaner, so all the surfaces need to be sanded. First, use a coarse sandpaper (e.g. 100-120 grit), and then sand with a fine sandpaper (e.g. 200-300 grit). It is important that you always sand with the grain, i.e. lengthwise. Both oiled and painted garden furniture must be sanded. This is necessary to create a fine, smooth surface before treating with oil, or to ensure that the paint adheres to the wood. If the furniture has marks or discolorations which have not been properly treated, or if the furniture has not been stored correctly, such marks and discolorations can often be removed by sanding. Any sanding dust should be removed before the next step.

Oiling/painting

Oiling/painting should be done in a relatively warm place (10-25°C), but not inside so you avoid inhaling oil fumes. Protect the wood with fungicidal oil or paint that will prevent mould and algae growth. If the garden furniture is going to be painted, the best result is achieved by first applying a layer of primer, which should always be allowed to dry until the following day. If the garden furniture is going to be oiled, it is a good idea to use a pigmented oil, which protects the wood against the sun's harmful UV rays. Evenly apply the wood oil or paint using a brush. Take care to saturate the end grain with oil/paint. If necessary, wipe off any small pools of surplus oil on horizontal surfaces with a cloth. These form when the wood is saturated with oil. The garden furniture must have at least two coats of oil/paint to ensure a satisfactory finish. Once the garden furniture has been treated, it should be left for a few days until the oil/paint is completely dry and can withstand the rain, sun and wind outside. The better the quality of the oil/paint, the better the result. Oil or paint can be purchased from paint shops, builders' merchants and DIY stores. Here, it is also possible to obtain professional advice on which type of oil/paint to use.

Please note!

IT IS IMPORTANT THAT GARDEN FURNITURE STANDS ON A FLAT SURFACE SO THAT ALL THE LEGS ARE IN CONTACT WITH THE GROUND.

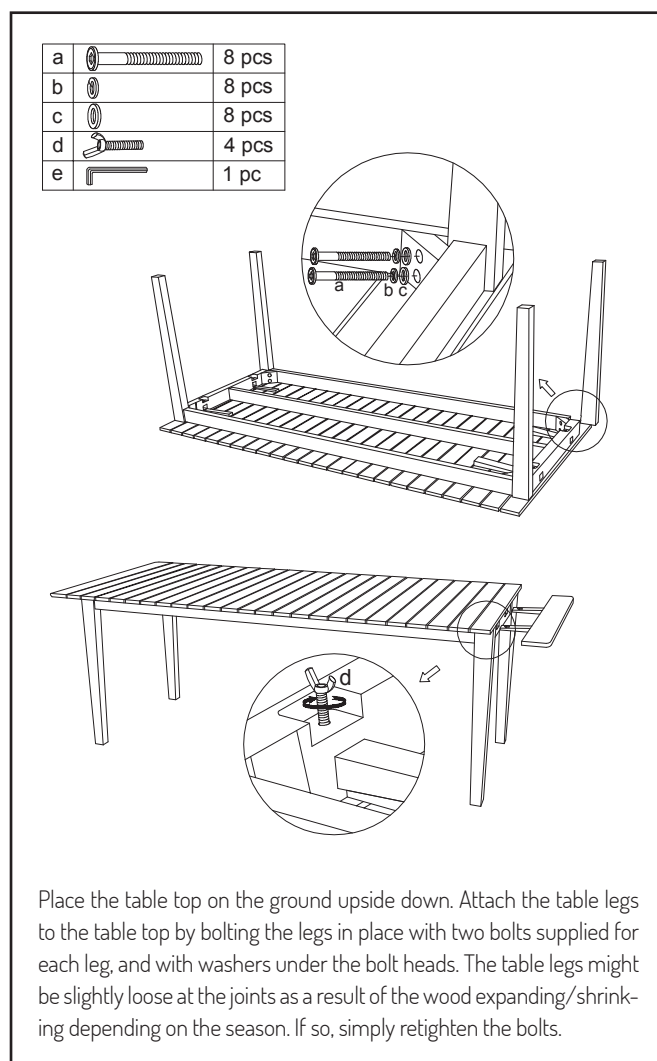

Place the table top on the ground upside down. Attach the table legs to the table top by bolting the legs in place with two bolts supplied for each leg, and with washers under the bolt heads. The table legs might be slightly loose at the joints as a result of the wood expanding/shrinking depending on the season. If so, simply retighten the bolts.



FDB Møbler is manufactured using only FSC-certified wood. FSC certification ensures that no more trees are felled than the forest can reproduce. At the same time, the FSC label guarantees that forest animals and plants are protected, and that the forest workers receive training, safety equipment and a reasonable pay. When you, the consumer, choose FSC, you are helping to protect the natural environment and ensure proper social conditions in the forests where the wood is sourced. In choosing products made with FSC wood, you are supporting forest owners who have chosen to manage their forests in a way that respects the people who work there and the fauna for which the forest is their habitat. For further information, visit www.fsc.dk.



MØBLER

- A PHILOSOPHY -

*“You ought to feel at home
in a piece of furniture”*

Quote: Thomas Alken

Dear Customer

FDB Møbler was founded out of a desire to create furniture that makes room for people – a philosophy which has been shaped in oak and beech and woven into seats since 1942. New generations of designers have joined the team since then, but the fundamental mission remains the same: To produce beautiful, functional pieces of furniture made to high standards of craftsmanship that make room for everyday life in living rooms, kitchens and children’s bedrooms. And which can withstand wear and tear, year in and year out. FDB Møbler wrote itself into the annals of Danish design history long ago with classics that

have been passed down for generations. So even if your furniture is brand new, it is already an heirloom, because it is imbued with all the values that we were born with, and which are still honoured to this day when we produce our classics, relaunch furniture from our design archives, or introduce brand-new designs. We hope you will be happy with your new purchase, and that it will enhance your quality of life, as this has been the intention ever since our first pieces of furniture emerged from the drawing board.

• M3 • Sammen – Dining table

Designer Thomas Alken

PRODUCT INFORMATION

This large garden table is perfect for spending time and socialising outdoors. Here, we come together for long lunches and cheerful bonhomie during the long summer evenings. FDB Møbler has produced countless dining tables over the years, and C201b should be seen as part of this tradition – just for outdoor use. The table has naturally rounded ends, with the ingenious detail that the ends can be detached, and then two tables can be joined using a table leaf.

Thomas Alken (b. 1970) graduated as a furniture and industrial designer from Design School Kolding in 1997. He has been involved in a wide range of design projects, from luxury furniture and ketchup bottles to a lounge at Copenhagen Airport, because it is the user situation that fascinates him. In his view, furniture must always be seen in a larger context. And with the ‘Sammen’ (Together) series, he has made sure that the furniture harmonises with the traditions of FDB Møbler as well as Danish gardens.

CARE INSTRUCTIONS

We always recommend that garden furniture is carefully looked after and maintained. In Denmark, humidity levels and large temperature fluctuations can cause wood to crack and warp. This means that mould, for example, is more likely to attack the wood. So, there are many good reasons why you should maintain your wooden garden furniture. The wood will retain its beautiful colour rather than becoming grey and dreary to look at. The garden furniture will be protected against degradation from the weather, wind and sun, and will therefore last longer. With proper treatment, teak garden furniture can last for many years. Teak contains a lot of natural oils and minerals, so teak furniture can to some extent be left untreated. Over time, the wood will acquire a silver-grey sur

face, as the rain and sun wash and dry out the top oil layer which is naturally found in the wood. However, to keep the wood healthy, it is a good idea to oil your furniture at least once a year. If you wish to retain the silver-grey finish, use natural oil without colour pigments.

Wooden garden furniture should be washed often to remove dust and dirt to prevent blotching etc. on the surface. If you want to retain the beautiful golden hue of new teak, it should be treated with oil one to three times a year like all other wood types, and with a teak oil containing colour pigments. Before bringing wooden garden furniture inside for the winter, it is important to clean it thoroughly to prevent rot and mould from developing. Retighten the bolts and screws if necessary. It is a good idea to end the season by oiling or painting the furniture. Wood is a living material, and therefore benefits from being stored in a shed, so it is not exposed to moisture during the winter. Wooden garden furniture should not be in direct contact with the ground, as the legs will absorb moisture. If necessary, place tiles under the legs, or make sure to wrap the tarpaulin under the legs of both chairs and tables. Wooden garden furniture does not benefit from being stored in a warm room during the winter, as the wood can dry out completely. This can cause large cracks, and the wood may shrink. When the time comes to take your garden furniture back out into the garden again, it is important that you tighten the screws, bolts and brackets which might have become loose during the winter.

Lubricate all moving parts with a neutral oil (for example sewing machine oil). Wash the garden furniture thoroughly. If the furniture was oiled or painted before being put away for the winter, it should now be ready for use. If not, it is a good idea to do so before starting to use the furniture again.



FDB Møbler is manufactured using only FSC-certified wood. FSC certification ensures that no more trees are felled than the forest can reproduce. At the same time, the FSC label guarantees that forest animals and plants are protected, and that the forest workers receive training, safety equipment and a reasonable pay. When you, the consumer, choose FSC, you are helping to protect the natural environment and ensure proper social conditions in the forests where the wood is sourced. In choosing products made with FSC wood, you are supporting forest owners who have chosen to manage their forests in a way that respects the people who work there and the fauna for which the forest is their habitat. For further information, visit www.fsc.dk.



MØBLER

- A PHILOSOPHY -

*“You ought to feel at home
in a piece of furniture”*

Quote: Thomas Alken

Cleaning

Garden furniture should be cleaned to remove any algae and dirt. It is important to make sure that the furniture is completely clean before it is oiled. Remove dirt, old oil, mould and algae using a stiff brush and plenty of water. Perhaps add a little wood cleaner to the water. However, remember to rinse the furniture thoroughly after washing. Different types of wood cleaner are available, for example wood cleaner for teak, which cleans the wood without removing the natural oils in the wood. Buy the products that are the most suitable for the garden furniture. If the wood is very worn or damaged, it can be deep-cleaned by means of a two-stage cleaning process: First, wash the wood thoroughly, and then neutralise the cleaning to reveal the wood's natural glow and appearance. It is important that the garden furniture dries properly before proceeding to the next step.

Sanding

Often the wood will rise after being soaked with water and cleaner, so all the surfaces need to be sanded. First, use a coarse sandpaper (e.g. 100-120 grit), and then sand with a fine sandpaper (e.g. 200-300 grit). It is important that you always sand with the grain, i.e. lengthwise. Both oiled and painted garden furniture must be sanded. This is necessary to create a fine, smooth surface before treating with oil, or to ensure that the paint adheres to the wood. If the furniture has marks or discolorations which have not been properly treated, or if the furniture has not been stored correctly, such marks and discolorations can often be removed by sanding. Any sanding dust should be removed before the next step.

Oiling/painting

Oiling/painting should be done in a relatively warm place (10-25°C), but not inside so you avoid inhaling oil fumes. Protect the wood with fungicidal oil or paint that will prevent mould and algae growth. If the garden furniture is going to be painted, the best result is achieved by first applying a layer of primer, which should always be allowed to dry until the following day. If the garden furniture is going to be oiled, it is a good idea to use a pigmented oil, which protects the wood against the sun's harmful UV rays. Evenly apply the wood oil or paint using a brush. Take care to saturate the end grain with oil/paint. If necessary, wipe off any small pools of surplus oil on horizontal surfaces with a cloth. These form when the wood is saturated with oil. The garden furniture must have at least two coats of oil/paint to ensure a satisfactory finish. Once the garden furniture has been treated, it should be left for a few days until the oil/paint is completely dry and can withstand the rain, sun and wind outside. The better the quality of the oil/paint, the better the result. Oil or paint can be purchased from paint shops, builders' merchants and DIY stores. Here, it is also possible to obtain professional advice on which type of oil/paint to use.

Please note!

IT IS IMPORTANT THAT GARDEN FURNITURE STANDS ON A FLAT SURFACE SO THAT ALL THE LEGS ARE IN CONTACT WITH THE GROUND.

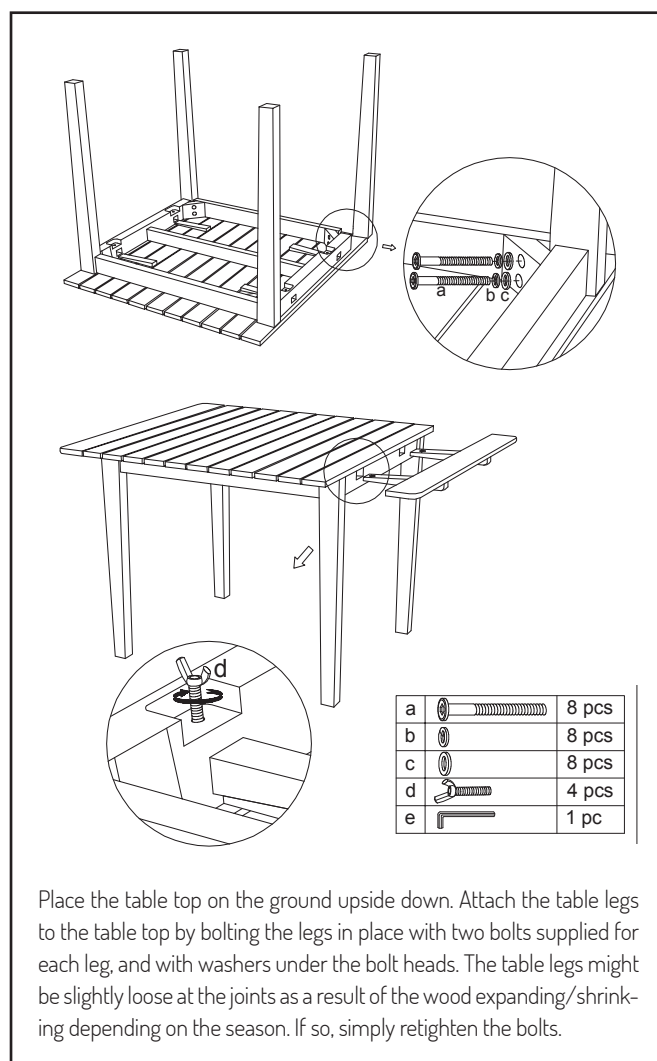

FDB Møbler is manufactured using only FSC-certified wood. FSC certification ensures that no more trees are felled than the forest can reproduce. At the same time, the FSC label guarantees that forest animals and plants are protected, and that the forest workers receive training, safety equipment and a reasonable pay. When you, the consumer, choose FSC, you are helping to protect the natural environment and ensure proper social conditions in the forests where the wood is sourced. In choosing products made with FSC wood, you are supporting forest owners who have chosen to manage their forests in a way that respects the people who work there and the fauna for which the forest is their habitat. For further information, visit www.fsc.dk.



MØBLER

- A PHILOSOPHY -

*“You ought to feel at home
in a piece of furniture”*

Quote: Thomas Alken

Dear Customer

FDB Møbler was founded out of a desire to create furniture that makes room for people – a philosophy which has been shaped in oak and beech and woven into seats since 1942. New generations of designers have joined the team since then, but the fundamental mission remains the same: To produce beautiful, functional pieces of furniture made to high standards of craftsmanship that make room for everyday life in living rooms, kitchens and children’s bedrooms. And which can withstand wear and tear, year in and year out. FDB Møbler wrote itself into the annals of Danish design history long ago with classics that

have been passed down for generations. So even if your furniture is brand new, it is already an heirloom, because it is imbued with all the values that we were born with, and which are still honoured to this day when we produce our classics, relaunch furniture from our design archives, or introduce brand-new designs. We hope you will be happy with your new purchase, and that it will enhance your quality of life, as this has been the intention ever since our first pieces of furniture emerged from the drawing board.

• M4 • Sammen - Table leaf

Designer Thomas Alken

PRODUCT INFORMATION

The table leaf for the M3 dining table is a smart accessory that makes it possible to turn two garden tables into a long table for large summer gatherings and parties. And no compromises have been made in terms of its design or table stability. The leaf fits both the small M3 garden table as well as the slightly larger M2 table. The leaf makes it possible to join as many tables as you want.

Thomas Alken (b. 1970) graduated as a furniture and industrial designer from Design School Kolding in 1997. He has been involved in a wide range of design projects, from luxury furniture and ketchup bottles to a lounge at Copenhagen Airport, because it is the user situation that fascinates him. In his view, furniture must always be seen in a larger context. And with the ‘Sammen’ (Together) series, he has made sure that the furniture harmonises with the traditions of FDB Møbler as well as Danish gardens.

CARE INSTRUCTIONS

We always recommend that garden furniture is carefully looked after and maintained. In Denmark, humidity levels and large temperature fluctuations can cause wood to crack and warp. This means that mould, for example, is more likely to attack the wood. So, there are many good reasons why you should maintain your wooden garden furniture. The wood will retain its beautiful colour rather than becoming grey and dreary to look at. The garden furniture will be protected against degradation from the weather, wind and sun, and will therefore last longer. With proper treatment, teak garden furniture can last for many years. Teak contains a lot of natural oils and minerals, so teak furniture can to some extent be left untreated. Over time, the wood will acquire a silver-grey sur-

face, as the rain and sun wash and dry out the top oil layer which is naturally found in the wood. However, to keep the wood healthy, it is a good idea to oil your furniture at least once a year. If you wish to retain the silver-grey finish, use natural oil without colour pigments.

Wooden garden furniture should be washed often to remove dust and dirt to prevent blotching etc. on the surface. If you want to retain the beautiful golden hue of new teak, it should be treated with oil one to three times a year like all other wood types, and with a teak oil containing colour pigments. Before bringing wooden garden furniture inside for the winter, it is important to clean it thoroughly to prevent rot and mould from developing. Retighten the bolts and screws if necessary. It is a good idea to end the season by oiling or painting the furniture. Wood is a living material, and therefore benefits from being stored in a shed, so it is not exposed to moisture during the winter. Wooden garden furniture should not be in direct contact with the ground, as the legs will absorb moisture. If necessary, place tiles under the legs, or make sure to wrap the tarpaulin under the legs of both chairs and tables. Wooden garden furniture does not benefit from being stored in a warm room during the winter, as the wood can dry out completely. This can cause large cracks, and the wood may shrink. When the time comes to take your garden furniture back out into the garden again, it is important that you tighten the screws, bolts and brackets which might have become loose during the winter.

Lubricate all moving parts with a neutral oil (for example sewing machine oil). Wash the garden furniture thoroughly. If the furniture was oiled or painted before being put away for the winter, it should now be ready for use. If not, it is a good idea to do so before starting to use the furniture again.



FDB Møbler is manufactured using only FSC-certified wood. FSC certification ensures that no more trees are felled than the forest can reproduce. At the same time, the FSC label guarantees that forest animals and plants are protected, and that the forest workers receive training, safety equipment and a reasonable pay. When you, the consumer, choose FSC, you are helping to protect the natural environment and ensure proper social conditions in the forests where the wood is sourced. In choosing products made with FSC wood, you are supporting forest owners who have chosen to manage their forests in a way that respects the people who work there and the fauna for which the forest is their habitat. For further information, visit www.fsc.dk.



MØBLER

- A PHILOSOPHY -

*“You ought to feel at home
in a piece of furniture”*

Quote: Thomas Alken

Cleaning

Garden furniture should be cleaned to remove any algae and dirt. It is important to make sure that the furniture is completely clean before it is oiled. Remove dirt, old oil, mould and algae using a stiff brush and plenty of water. Perhaps add a little wood cleaner to the water. However, remember to rinse the furniture thoroughly after washing. Different types of wood cleaner are available, for example wood cleaner for teak, which cleans the wood without removing the natural oils in the wood. Buy the products that are the most suitable for the garden furniture. If the wood is very worn or damaged, it can be deep-cleaned by means of a two-stage cleaning process: First, wash the wood thoroughly, and then neutralise the cleaning to reveal the wood's natural glow and appearance. It is important that the garden furniture dries properly before proceeding to the next step.

Sanding

Often the wood will rise after being soaked with water and cleaner, so all the surfaces need to be sanded. First, use a coarse sandpaper (e.g. 100-120 grit), and then sand with a fine sandpaper (e.g. 200-300 grit). It is important that you always sand with the grain, i.e. lengthwise. Both oiled and painted garden furniture must be sanded. This is necessary to create a fine, smooth surface before treating with oil, or to ensure that the paint adheres to the wood. If the furniture has marks or discolorations which have not been properly treated, or if the furniture has not been stored correctly, such marks and discolorations can often be removed by sanding. Any sanding dust should be removed before the next step.

Oiling/painting

Oiling/painting should be done in a relatively warm place (10-25°C), but not inside so you avoid inhaling oil fumes. Protect the wood with fungicidal oil or paint that will prevent mould and algae growth. If the garden furniture is going to be painted, the best result is achieved by first applying a layer of primer, which should always be allowed to dry until the following day. If the garden furniture is going to be oiled, it is a good idea to use a pigmented oil, which protects the wood against the sun's harmful UV rays. Evenly apply the wood oil or paint using a brush. Take care to saturate the end grain with oil/paint. If necessary, wipe off any small pools of surplus oil on horizontal surfaces with a cloth. These form when the wood is saturated with oil. The garden furniture must have at least two coats of oil/paint to ensure a satisfactory finish. Once the garden furniture has been treated, it should be left for a few days until the oil/paint is completely dry and can withstand the rain, sun and wind outside. The better the quality of the oil/paint, the better the result. Oil or paint can be purchased from paint shops, builders' merchants and DIY stores. Here, it is also possible to obtain professional advice on which type of oil/paint to use.

Please note!

IT IS IMPORTANT THAT GARDEN FURNITURE STANDS ON A FLAT SURFACE SO THAT ALL THE LEGS ARE IN CONTACT WITH THE GROUND.



FDB Møbler is manufactured using only FSC-certified wood. FSC certification ensures that no more trees are felled than the forest can reproduce. At the same time, the FSC label guarantees that forest animals and plants are protected, and that the forest workers receive training, safety equipment and a reasonable pay. When you, the consumer, choose FSC, you are helping to protect the natural environment and ensure proper social conditions in the forests where the wood is sourced. In choosing products made with FSC wood, you are supporting forest owners who have chosen to manage their forests in a way that respects the people who work there and the fauna for which the forest is their habitat. For further information, visit www.fsc.dk.



MØBLER

- A PHILOSOPHY -

*“You ought to feel at home
in a piece of furniture”*

Quote: Thomas Alken

Dear Customer

FDB Møbler was founded out of a desire to create furniture that makes room for people – a philosophy which has been shaped in oak and beech and woven into seats since 1942. New generations of designers have joined the team since then, but the fundamental mission remains the same: To produce beautiful, functional pieces of furniture made to high standards of craftsmanship that make room for everyday life in living rooms, kitchens and children’s bedrooms. And which can withstand wear and tear, year in and year out. FDB Møbler wrote itself into the annals of Danish design history long ago with classics that

have been passed down for generations. So even if your furniture is brand new, it is already an heirloom, because it is imbued with all the values that we were born with, and which are still honoured to this day when we produce our classics, relaunch furniture from our design archives, or introduce brand-new designs. We hope you will be happy with your new purchase, and that it will enhance your quality of life, as this has been the intention ever since our first pieces of furniture emerged from the drawing board.

• M5 • Sammen - Table leaf

Designer Thomas Alken

PRODUCT INFORMATION

The table leaf for the M3 dining table is a smart accessory that makes it possible to turn two garden tables into a long table for large summer gatherings and parties. And no compromises have been made in terms of its design or table stability. The leaf fits both the small M3 garden table as well as the slightly larger M2 table. The leaf makes it possible to join as many tables as you want.

Thomas Alken (b. 1970) graduated as a furniture and industrial designer from Design School Kolding in 1997. He has been involved in a wide range of design projects, from luxury furniture and ketchup bottles to a lounge at Copenhagen Airport, because it is the user situation that fascinates him. In his view, furniture must always be seen in a larger context. And with the ‘Sammen’ (Together) series, he has made sure that the furniture harmonises with the traditions of FDB Møbler as well as Danish gardens.

CARE INSTRUCTIONS

We always recommend that garden furniture is carefully looked after and maintained. In Denmark, humidity levels and large temperature fluctuations can cause wood to crack and warp. This means that mould, for example, is more likely to attack the wood. So, there are many good reasons why you should maintain your wooden garden furniture. The wood will retain its beautiful colour rather than becoming grey and dreary to look at. The garden furniture will be protected against degradation from the weather, wind and sun, and will therefore last longer. With proper treatment, teak garden furniture can last for many years. Teak contains a lot of natural oils and minerals, so teak furniture can to some extent be left untreated. Over time, the wood will acquire a silver-grey sur-

face, as the rain and sun wash and dry out the top oil layer which is naturally found in the wood. However, to keep the wood healthy, it is a good idea to oil your furniture at least once a year. If you wish to retain the silver-grey finish, use natural oil without colour pigments.

Wooden garden furniture should be washed often to remove dust and dirt to prevent blotching etc. on the surface. If you want to retain the beautiful golden hue of new teak, it should be treated with oil one to three times a year like all other wood types, and with a teak oil containing colour pigments. Before bringing wooden garden furniture inside for the winter, it is important to clean it thoroughly to prevent rot and mould from developing. Retighten the bolts and screws if necessary. It is a good idea to end the season by oiling or painting the furniture. Wood is a living material, and therefore benefits from being stored in a shed, so it is not exposed to moisture during the winter. Wooden garden furniture should not be in direct contact with the ground, as the legs will absorb moisture. If necessary, place tiles under the legs, or make sure to wrap the tarpaulin under the legs of both chairs and tables. Wooden garden furniture does not benefit from being stored in a warm room during the winter, as the wood can dry out completely. This can cause large cracks, and the wood may shrink. When the time comes to take your garden furniture back out into the garden again, it is important that you tighten the screws, bolts and brackets which might have become loose during the winter.

Lubricate all moving parts with a neutral oil (for example sewing machine oil). Wash the garden furniture thoroughly. If the furniture was oiled or painted before being put away for the winter, it should now be ready for use. If not, it is a good idea to do so before starting to use the furniture again.



FDB Møbler is manufactured using only FSC-certified wood. FSC certification ensures that no more trees are felled than the forest can reproduce. At the same time, the FSC label guarantees that forest animals and plants are protected, and that the forest workers receive training, safety equipment and a reasonable pay. When you, the consumer, choose FSC, you are helping to protect the natural environment and ensure proper social conditions in the forests where the wood is sourced. In choosing products made with FSC wood, you are supporting forest owners who have chosen to manage their forests in a way that respects the people who work there and the fauna for which the forest is their habitat. For further information, visit www.fsc.dk.



MØBLER

- A PHILOSOPHY -

*“You ought to feel at home
in a piece of furniture”*

Quote: Thomas Alken

Cleaning

Garden furniture should be cleaned to remove any algae and dirt. It is important to make sure that the furniture is completely clean before it is oiled. Remove dirt, old oil, mould and algae using a stiff brush and plenty of water. Perhaps add a little wood cleaner to the water. However, remember to rinse the furniture thoroughly after washing. Different types of wood cleaner are available, for example wood cleaner for teak, which cleans the wood without removing the natural oils in the wood. Buy the products that are the most suitable for the garden furniture. If the wood is very worn or damaged, it can be deep-cleaned by means of a two-stage cleaning process: First, wash the wood thoroughly, and then neutralise the cleaning to reveal the wood's natural glow and appearance. It is important that the garden furniture dries properly before proceeding to the next step.

Sanding

Often the wood will rise after being soaked with water and cleaner, so all the surfaces need to be sanded. First, use a coarse sandpaper (e.g. 100-120 grit), and then sand with a fine sandpaper (e.g. 200-300 grit). It is important that you always sand with the grain, i.e. lengthwise. Both oiled and painted garden furniture must be sanded. This is necessary to create a fine, smooth surface before treating with oil, or to ensure that the paint adheres to the wood. If the furniture has marks or discolorations which have not been properly treated, or if the furniture has not been stored correctly, such marks and discolorations can often be removed by sanding. Any sanding dust should be removed before the next step.

Oiling/painting

Oiling/painting should be done in a relatively warm place (10-25°C), but not inside so you avoid inhaling oil fumes. Protect the wood with fungicidal oil or paint that will prevent mould and algae growth. If the garden furniture is going to be painted, the best result is achieved by first applying a layer of primer, which should always be allowed to dry until the following day. If the garden furniture is going to be oiled, it is a good idea to use a pigmented oil, which protects the wood against the sun's harmful UV rays. Evenly apply the wood oil or paint using a brush. Take care to saturate the end grain with oil/paint. If necessary, wipe off any small pools of surplus oil on horizontal surfaces with a cloth. These form when the wood is saturated with oil. The garden furniture must have at least two coats of oil/paint to ensure a satisfactory finish. Once the garden furniture has been treated, it should be left for a few days until the oil/paint is completely dry and can withstand the rain, sun and wind outside. The better the quality of the oil/paint, the better the result. Oil or paint can be purchased from paint shops, builders' merchants and DIY stores. Here, it is also possible to obtain professional advice on which type of oil/paint to use.

Please note!

IT IS IMPORTANT THAT GARDEN FURNITURE STANDS ON A FLAT SURFACE SO THAT ALL THE LEGS ARE IN CONTACT WITH THE GROUND.



FDB Møbler is manufactured using only FSC-certified wood. FSC certification ensures that no more trees are felled than the forest can reproduce. At the same time, the FSC label guarantees that forest animals and plants are protected, and that the forest workers receive training, safety equipment and a reasonable pay. When you, the consumer, choose FSC, you are helping to protect the natural environment and ensure proper social conditions in the forests where the wood is sourced. In choosing products made with FSC wood, you are supporting forest owners who have chosen to manage their forests in a way that respects the people who work there and the fauna for which the forest is their habitat. For further information, visit www.fsc.dk.



MØBLER

- A PHILOSOPHY -

*“You ought to feel at home
in a piece of furniture”*

Quote: Thomas Alken

Dear Customer

FDB Møbler was founded out of a desire to create furniture that makes room for people – a philosophy which has been shaped in oak and beech and woven into seats since 1942. New generations of designers have joined the team since then, but the fundamental mission remains the same: To produce beautiful, functional pieces of furniture made to high standards of craftsmanship that make room for everyday life in living rooms, kitchens and children's bedrooms. And which can withstand wear and tear, year in and year out. FDB Møbler wrote itself into the annals of Danish design history long ago with classics that

have been passed down for generations. So even if your furniture is brand new, it is already an heirloom, because it is imbued with all the values that we were born with, and which are still honoured to this day when we produce our classics, relaunch furniture from our design archives, or introduce brand-new designs. We hope you will be happy with your new purchase, and that it will enhance your quality of life, as this has been the intention ever since our first pieces of furniture emerged from the drawing board.

• M6 • Sammen – Lounge chair

Designer Thomas Alken

PRODUCT INFORMATION

The lounge chair is designed for those who enjoy spending time outdoors in the garden. With a warm blanket and a cup of tea in the early spring sunshine. Or with a book and a cold drink on a hot summer's day. FDB Møbler has created a garden chair with many of the same qualities as its indoor lounge chair. A relaxed and comfortable chair, yet with the same classic lines and simple, understated design that characterises furniture from FDB Møbler. Thomas Alken, who has designed the entire 'Sammen' series, has for many years been designing lounge chairs which represent challenging and new takes on the designs of the greatest Danish furniture designers. However, this is his first lounge chair for outdoor use.

Thomas Alken (b. 1970) graduated as a furniture and industrial designer from Design School Kolding in 1997. He has been involved in a wide range of design projects, from luxury furniture and ketchup bottles to a lounge at Copenhagen Airport, because it is the user situation that fascinates him. In his view, furniture must always be seen in a larger context. And with the 'Sammen' (Together) series, he has made sure that the furniture harmonises with the traditions of FDB Møbler as well as Danish gardens.

CARE INSTRUCTIONS

We always recommend that garden furniture is carefully looked after and maintained. In Denmark, humidity levels and large temperature fluctuations can cause wood to crack and warp. This means that mould, for example, is more likely to attack the wood. So, there are many good reasons why you should maintain your wooden garden furniture. The wood will retain its beautiful colour rather than becoming grey and dreary to look at. The garden furniture will be protected

against degradation from the weather, wind and sun, and will therefore last longer. With proper treatment, teak garden furniture can last for many years. Teak contains a lot of natural oils and minerals, so teak furniture can to some extent be left untreated. Over time, the wood will acquire a silver-grey surface, as the rain and sun wash and dry out the top oil layer which is naturally found in the wood. However, to keep the wood healthy, it is a good idea to oil your furniture at least once a year. If you wish to retain the silver-grey finish, use natural oil without colour pigments.

Wooden garden furniture should be washed often to remove dust and dirt to prevent blotching etc. on the surface. If you want to retain the beautiful golden hue of new teak, it should be treated with oil one to three times a year like all other wood types, and with a teak oil containing colour pigments. Before bringing wooden garden furniture inside for the winter, it is important to clean it thoroughly to prevent rot and mould from developing. Retighten the bolts and screws if necessary. It is a good idea to end the season by oiling or painting the furniture. Wood is a living material, and therefore benefits from being stored in a shed, so it is not exposed to moisture during the winter. Wooden garden furniture should not be in direct contact with the ground, as the legs will absorb moisture. If necessary, place tiles under the legs, or make sure to wrap the tarpaulin under the legs of both chairs and tables. Wooden garden furniture does not benefit from being stored in a warm room during the winter, as the wood can dry out completely. This can cause large cracks, and the wood may shrink. When the time comes to take your garden furniture back out into the garden again, it is important that you tighten the screws, bolts and brackets which might have become loose during the winter.



FDB Møbler is manufactured using only FSC-certified wood. FSC certification ensures that no more trees are felled than the forest can reproduce. At the same time, the FSC label guarantees that forest animals and plants are protected, and that the forest workers receive training, safety equipment and a reasonable pay. When you, the consumer, choose FSC, you are helping to protect the natural environment and ensure proper social conditions in the forests where the wood is sourced. In choosing products made with FSC wood, you are supporting forest owners who have chosen to manage their forests in a way that respects the people who work there and the fauna for which the forest is their habitat. For further information, visit www.fsc.dk.



MØBLER

- A PHILOSOPHY -

*“You ought to feel at home
in a piece of furniture”*

Quote: Thomas Alken

Lubricate all moving parts with a neutral oil (for example sewing machine oil). Wash the garden furniture thoroughly. If the furniture was oiled or painted before being put away for the winter, it should now be ready for use. If not, it is a good idea to do so before starting to use the furniture again.

Cleaning

Garden furniture should be cleaned to remove any algae and dirt. It is important to make sure that the furniture is completely clean before it is oiled. Remove dirt, old oil, mould and algae using a stiff brush and plenty of water. Perhaps add a little wood cleaner to the water. However, remember to rinse the furniture thoroughly after washing. Different types of wood cleaner are available, for example wood cleaner for teak, which cleans the wood without removing the natural oils in the wood. Buy the products that are the most suitable for the garden furniture. If the wood is very worn or damaged, it can be deep-cleaned by means of a two-stage cleaning process: First, wash the wood thoroughly, and then neutralise the cleaning to reveal the wood's natural glow and appearance. It is important that the garden furniture dries properly before proceeding to the next step.

Sanding

Often the wood will rise after being soaked with water and cleaner, so all the surfaces need to be sanded. First, use a coarse sandpaper (e.g. 100-120 grit), and then sand with a fine sandpaper (e.g. 200-300 grit). It is important that you always sand with the grain, i.e. lengthwise. Both oiled and painted garden furniture must be sanded. This is necessary to create a fine, smooth surface before treating with oil, or to ensure that the paint adheres to the wood. If the furniture has marks or discolorations which have not been properly treated, or if the furniture has not been stored correctly, such marks and discolorations can often be removed by sanding. Any sanding dust should be removed before the next step.

Oiling/painting

Oiling/painting should be done in a relatively warm place (10-25°C), but not inside so you avoid inhaling oil fumes. Protect the wood with fungicidal oil or paint that will prevent mould and algae growth. If the garden furniture is going to be painted, the best result is achieved by first applying a layer of primer, which should always be allowed to dry until the following day. If the garden furniture is going to be oiled, it is a good idea to use a pigmented oil, which protects the wood against the sun's harmful UV rays. Evenly apply the wood oil or paint using a brush. Take care to saturate the end grain with oil/paint. If necessary, wipe off any small pools of surplus oil on horizontal surfaces with a cloth. These form when the wood is saturated with oil. The garden furniture must have at least two coats of oil/paint to ensure a satisfactory finish. Once the garden furniture has been treated, it should be left for a few days until the

oil/paint is completely dry and can withstand the rain, sun and wind outside. The better the quality of the oil/paint, the better the result. Oil or paint can be purchased from paint shops, builders' merchants and DIY stores. Here, it is also possible to obtain professional advice on which type of oil/paint to use.

Please note!

IT IS IMPORTANT THAT GARDEN FURNITURE STANDS ON A FLAT SURFACE SO THAT ALL THE LEGS ARE IN CONTACT WITH THE GROUND.



FDB Møbler is manufactured using only FSC-certified wood. FSC certification ensures that no more trees are felled than the forest can reproduce. At the same time, the FSC label guarantees that forest animals and plants are protected, and that the forest workers receive training, safety equipment and a reasonable pay. When you, the consumer, choose FSC, you are helping to protect the natural environment and ensure proper social conditions in the forests where the wood is sourced. In choosing products made with FSC wood, you are supporting forest owners who have chosen to manage their forests in a way that respects the people who work there and the fauna for which the forest is their habitat. For further information, visit www.fsc.dk.



MØBLER

- A PHILOSOPHY -

*“You ought to feel at home
in a piece of furniture”*

Quote: Thomas Alken

Dear Customer

FDB Møbler was founded out of a desire to create furniture that makes room for people – a philosophy which has been shaped in oak and beech and woven into seats since 1942. New generations of designers have joined the team since then, but the fundamental mission remains the same: To produce beautiful, functional pieces of furniture made to high standards of craftsmanship that make room for everyday life in living rooms, kitchens and children’s bedrooms. And which can withstand wear and tear, year in and year out. FDB Møbler wrote itself into the annals of Danish design history long ago with classics that

have been passed down for generations. So even if your furniture is brand new, it is already an heirloom, because it is imbued with all the values that we were born with, and which are still honoured to this day when we produce our classics, relaunch furniture from our design archives, or introduce brand-new designs. We hope you will be happy with your new purchase, and that it will enhance your quality of life, as this has been the intention ever since our first pieces of furniture emerged from the drawing board.

• M7 • Sammen – Footstool

Designer Thomas Alken

PRODUCT INFORMATION

Great design is all in the detail. The footstool does not usually receive much attention when it comes to garden furniture. However, the footstool in the ‘Sammen’ series is more than just somewhere to place your feet when seated in a garden chair. In terms of its design and craftsmanship, the footstool is a perfect match for the rest of the series, as well as upholding FDB Møbler’s proud furniture-making traditions. As an extra detail, it transforms into a small table when you place the ‘Sammen’ tray on top of it – a small side table with its own distinctive look.

Thomas Alken (b. 1970) graduated as a furniture and industrial designer from Design School Kolding in 1997. He has been involved in a wide range of design projects, from luxury furniture and ketchup bottles to a lounge at Copenhagen Airport, because it is the user situation that fascinates him. In his view, furniture must always be seen in a larger context. And with the ‘Sammen’ (Together) series, he has made sure that the furniture harmonises with the traditions of FDB Møbler as well as Danish gardens.

CARE INSTRUCTIONS

We always recommend that garden furniture is carefully looked after and maintained. In Denmark, humidity levels and large temperature fluctuations can cause wood to crack and warp. This means that mould, for example, is more likely to attack the wood. So, there are many good reasons why you should maintain your wooden garden furniture. The wood will retain its beautiful colour rather than becoming grey and dreary to look at. The garden furniture will be protected against degradation from the weather, wind and sun, and will therefore last longer. With proper treatment, teak garden furniture can last for many years.

Teak contains a lot of natural oils and minerals, so teak furniture can to some extent be left untreated. Over time, the wood will acquire a silver-grey surface, as the rain and sun wash and dry out the top oil layer which is naturally found in the wood. However, to keep the wood healthy, it is a good idea to oil your furniture at least once a year. If you wish to retain the silver-grey finish, use natural oil without colour pigments.

Wooden garden furniture should be washed often to remove dust and dirt to prevent blotching etc. on the surface. If you want to retain the beautiful golden hue of new teak, it should be treated with oil one to three times a year like all other wood types, and with a teak oil containing colour pigments. Before bringing wooden garden furniture inside for the winter, it is important to clean it thoroughly to prevent rot and mould from developing. Retighten the bolts and screws if necessary. It is a good idea to end the season by oiling or painting the furniture. Wood is a living material, and therefore benefits from being stored in a shed, so it is not exposed to moisture during the winter. Wooden garden furniture should not be in direct contact with the ground, as the legs will absorb moisture. If necessary, place tiles under the legs, or make sure to wrap the tarpaulin under the legs of both chairs and tables. Wooden garden furniture does not benefit from being stored in a warm room during the winter, as the wood can dry out completely. This can cause large cracks, and the wood may shrink. When the time comes to take your garden furniture back out into the garden again, it is important that you tighten the screws, bolts and brackets which might have become loose during the winter.

Lubricate all moving parts with a neutral oil (for example sewing machine oil). Wash the garden furniture thoroughly. If the furniture was oiled or painted



FDB Møbler is manufactured using only FSC-certified wood. FSC certification ensures that no more trees are felled than the forest can reproduce. At the same time, the FSC label guarantees that forest animals and plants are protected, and that the forest workers receive training, safety equipment and a reasonable pay. When you, the consumer, choose FSC, you are helping to protect the natural environment and ensure proper social conditions in the forests where the wood is sourced. In choosing products made with FSC wood, you are supporting forest owners who have chosen to manage their forests in a way that respects the people who work there and the fauna for which the forest is their habitat. For further information, visit www.fsc.dk.



MØBLER

- A PHILOSOPHY -

*“You ought to feel at home
in a piece of furniture”*

Quote: Thomas Alken

before being put away for the winter, it should now be ready for use. If not, it is a good idea to do so before starting to use the furniture again.

Cleaning

Garden furniture should be cleaned to remove any algae and dirt. It is important to make sure that the furniture is completely clean before it is oiled. Remove dirt, old oil, mould and algae using a stiff brush and plenty of water. Perhaps add a little wood cleaner to the water. However, remember to rinse the furniture thoroughly after washing. Different types of wood cleaner are available, for example wood cleaner for teak, which cleans the wood without removing the natural oils in the wood. Buy the products that are the most suitable for the garden furniture. If the wood is very worn or damaged, it can be deep-cleaned by means of a two-stage cleaning process: First, wash the wood thoroughly, and then neutralise the cleaning to reveal the wood's natural glow and appearance. It is important that the garden furniture dries properly before proceeding to the next step.

Sanding

Often the wood will rise after being soaked with water and cleaner, so all the surfaces need to be sanded. First, use a coarse sandpaper (e.g. 100-120 grit), and then sand with a fine sandpaper (e.g. 200-300 grit). It is important that you always sand with the grain, i.e. lengthwise. Both oiled and painted garden furniture must be sanded. This is necessary to create a fine, smooth surface before treating with oil, or to ensure that the paint adheres to the wood. If the furniture has marks or discolorations which have not been properly treated, or if the furniture has not been stored correctly, such marks and discolorations can often be removed by sanding. Any sanding dust should be removed before the next step.

Oiling/painting

Oiling/painting should be done in a relatively warm place (10-25°C), but not inside so you avoid inhaling oil fumes. Protect the wood with fungicidal oil or paint that will prevent mould and algae growth. If the garden furniture is going to be painted, the best result is achieved by first applying a layer of primer, which should always be allowed to dry until the following day. If the garden furniture is going to be oiled, it is a good idea to use a pigmented oil, which protects the wood against the sun's harmful UV rays. Evenly apply the wood oil or paint using a brush. Take care to saturate the end grain with oil/paint. If necessary, wipe off any small pools of surplus oil on horizontal surfaces with a cloth. These form when the wood is saturated with oil. The garden furniture must have at least two coats of oil/paint to ensure a satisfactory finish. Once the garden furniture has been treated, it should be left for a few days until the oil/paint is completely dry and can withstand the rain, sun and wind outside. The better the quality of the oil/paint, the better the result. Oil or paint can be

purchased from paint shops, builders' merchants and DIY stores. Here, it is also possible to obtain professional advice on which type of oil/paint to use.

Please note!

IT IS IMPORTANT THAT GARDEN FURNITURE STANDS ON A FLAT SURFACE SO THAT ALL THE LEGS ARE IN CONTACT WITH THE GROUND.



FDB Møbler is manufactured using only FSC-certified wood. FSC certification ensures that no more trees are felled than the forest can reproduce. At the same time, the FSC label guarantees that forest animals and plants are protected, and that the forest workers receive training, safety equipment and a reasonable pay. When you, the consumer, choose FSC, you are helping to protect the natural environment and ensure proper social conditions in the forests where the wood is sourced. In choosing products made with FSC wood, you are supporting forest owners who have chosen to manage their forests in a way that respects the people who work there and the fauna for which the forest is their habitat. For further information, visit www.fsc.dk.



MØBLER

- A PHILOSOPHY -

*“You ought to feel at home
in a piece of furniture”*

Quote: Thomas Alken

Dear Customer

FDB Møbler was founded out of a desire to create furniture that makes room for people – a philosophy which has been shaped in oak and beech and woven into seats since 1942. New generations of designers have joined the team since then, but the fundamental mission remains the same: To produce beautiful, functional pieces of furniture made to high standards of craftsmanship that make room for everyday life in living rooms, kitchens and children's bedrooms. And which can withstand wear and tear, year in and year out. FDB Møbler wrote itself into the annals of Danish design history long ago with classics that

have been passed down for generations. So even if your furniture is brand new, it is already an heirloom, because it is imbued with all the values that we were born with, and which are still honoured to this day when we produce our classics, relaunch furniture from our design archives, or introduce brand-new designs. We hope you will be happy with your new purchase, and that it will enhance your quality of life, as this has been the intention ever since our first pieces of furniture emerged from the drawing board.

• M8 • Sammen – Chaise

Designer Thomas Alken

PRODUCT INFORMATION

Thomas Alken (b. 1970) graduated as a furniture and industrial designer from Design School Kolding in 1997. He has been involved in a wide range of design projects, from luxury furniture and ketchup bottles to a lounge at Copenhagen Airport, because it is the user situation that fascinates him. In his view, furniture must always be seen in a larger context. And with the 'Sammen' (Together) series, he has made sure that the furniture harmonises with the traditions of FDB Møbler as well as Danish gardens.

CARE INSTRUCTIONS

We always recommend that garden furniture is carefully looked after and maintained. In Denmark, humidity levels and large temperature fluctuations can cause wood to crack and warp. This means that mould, for example, is more likely to attack the wood. So, there are many good reasons why you should maintain your wooden garden furniture. The wood will retain its beautiful colour rather than becoming grey and dreary to look at. The garden furniture will be protected against degradation from the weather, wind and sun, and will therefore last longer. With proper treatment, teak garden furniture can last for many years.

Teak contains a lot of natural oils and minerals, so teak furniture can to some extent be left untreated. Over time, the wood will acquire a silver-grey surface, as the rain and sun wash and dry out the top oil layer which is naturally found in the wood. However, to keep the wood healthy, it is a good idea to oil your furniture at least once a year. If you wish to retain the silver-grey finish, use natural oil without colour pigments. Wooden garden furniture should be washed often to remove dust and dirt to prevent blotching etc. on the surface. If you want to retain the beautiful golden hue of new teak, it should

be treated with oil one to three times a year like all other wood types, and with a teak oil containing colour pigments. Before bringing wooden garden furniture inside for the winter, it is important to clean it thoroughly to prevent rot and mould from developing. Retighten the bolts and screws if necessary. It is a good idea to end the season by oiling or painting the furniture. Wood is a living material, and therefore benefits from being stored in a shed, so it is not exposed to moisture during the winter. Wooden garden furniture should not be in direct contact with the ground, as the legs will absorb moisture. If necessary, place tiles under the legs, or make sure to wrap the tarpaulin under the legs of both chairs and tables. Wooden garden furniture does not benefit from being stored in a warm room during the winter, as the wood can dry out completely. This can cause large cracks, and the wood may shrink. When the time comes to take your garden furniture back out into the garden again, it is important that you tighten the screws, bolts and brackets which might have become loose during the winter.

Lubricate all moving parts with a neutral oil (for example sewing machine oil). Wash the garden furniture thoroughly. If the furniture was oiled or painted before being put away for the winter, it should now be ready for use. If not, it is a good idea to do so before starting to use the furniture again.

Cleaning

Garden furniture should be cleaned to remove any algae and dirt. It is important to make sure that the furniture is completely clean before it is oiled. Remove dirt, old oil, mould and algae using a stiff brush and plenty of water. Perhaps add a little wood cleaner to the water. However, remember to rinse the furniture thoroughly after washing. Different types of wood cleaner are



FDB Møbler is manufactured using only FSC-certified wood. FSC certification ensures that no more trees are felled than the forest can reproduce. At the same time, the FSC label guarantees that forest animals and plants are protected, and that the forest workers receive training, safety equipment and a reasonable pay. When you, the consumer, choose FSC, you are helping to protect the natural environment and ensure proper social conditions in the forests where the wood is sourced. In choosing products made with FSC wood, you are supporting forest owners who have chosen to manage their forests in a way that respects the people who work there and the fauna for which the forest is their habitat. For further information, visit www.fsc.dk.



MØBLER

- A PHILOSOPHY -

*“You ought to feel at home
in a piece of furniture”*

Quote: Thomas Alken

available, for example wood cleaner for teak, which cleans the wood without removing the natural oils in the wood. Buy the products that are the most suitable for the garden furniture. If the wood is very worn or damaged, it can be deep-cleaned by means of a two-stage cleaning process: First, wash the wood thoroughly, and then neutralise the cleaning to reveal the wood's natural glow and appearance. It is important that the garden furniture dries properly before proceeding to the next step.

Sanding

Often the wood will rise after being soaked with water and cleaner, so all the surfaces need to be sanded. First, use a coarse sandpaper (e.g. 100-120 grit), and then sand with a fine sandpaper (e.g. 200-300 grit). It is important that you always sand with the grain, i.e. lengthwise. Both oiled and painted garden furniture must be sanded. This is necessary to create a fine, smooth surface before treating with oil, or to ensure that the paint adheres to the wood. If the furniture has marks or discolorations which have not been properly treated, or if the furniture has not been stored correctly, such marks and discolorations can often be removed by sanding. Any sanding dust should be removed before the next step.

Oiling/painting

Oiling/painting should be done in a relatively warm place (10-25°C), but not inside so you avoid inhaling oil fumes. Protect the wood with fungicidal oil or paint that will prevent mould and algae growth. If the garden furniture is going to be painted, the best result is achieved by first applying a layer of primer, which should always be allowed to dry until the following day. If the garden furniture is going to be oiled, it is a good idea to use a pigmented oil, which protects the wood against the sun's harmful UV rays. Evenly apply the wood oil or paint using a brush. Take care to saturate the end grain with oil/paint. If necessary, wipe off any small pools of surplus oil on horizontal surfaces with a cloth. These form when the wood is saturated with oil. The garden furniture must have at least two coats of oil/paint to ensure a satisfactory finish. Once the garden furniture has been treated, it should be left for a few days until the oil/paint is completely dry and can withstand the rain, sun and wind outside. The better the quality of the oil/paint, the better the result. Oil or paint can be purchased from paint shops, builders' merchants and DIY stores. Here, it is also possible to obtain professional advice on which type of oil/paint to use.

Please note!

IT IS IMPORTANT THAT GARDEN FURNITURE STANDS ON A FLAT SURFACE SO THAT ALL THE LEGS ARE IN CONTACT WITH THE GROUND.



FDB Møbler is manufactured using only FSC-certified wood. FSC certification ensures that no more trees are felled than the forest can reproduce. At the same time, the FSC label guarantees that forest animals and plants are protected, and that the forest workers receive training, safety equipment and a reasonable pay. When you, the consumer, choose FSC, you are helping to protect the natural environment and ensure proper social conditions in the forests where the wood is sourced. In choosing products made with FSC wood, you are supporting forest owners who have chosen to manage their forests in a way that respects the people who work there and the fauna for which the forest is their habitat. For further information, visit www.fsc.dk.



MØBLER

- A PHILOSOPHY -

*“You ought to feel at home
in a piece of furniture”*

Quote: Thomas Alken

Dear Customer

FDB Møbler was founded out of a desire to create furniture that makes room for people – a philosophy which has been shaped in oak and beech and woven into seats since 1942. New generations of designers have joined the team since then, but the fundamental mission remains the same: To produce beautiful, functional pieces of furniture made to high standards of craftsmanship that make room for everyday life in living rooms, kitchens and children’s bedrooms. And which can withstand wear and tear, year in and year out. FDB Møbler wrote itself into the annals of Danish design history long ago with classics that

have been passed down for generations. So even if your furniture is brand new, it is already an heirloom, because it is imbued with all the values that we were born with, and which are still honoured to this day when we produce our classics, relaunch furniture from our design archives, or introduce brand-new designs. We hope you will be happy with your new purchase, and that it will enhance your quality of life, as this has been the intention ever since our first pieces of furniture emerged from the drawing board.

• M9 • Sammen - Tray

Designer Thomas Alken

PRODUCT INFORMATION

When moving into the garden, it is often useful if the furniture has more than one function. The furniture will invariably need to be taken in and out in the course of a capricious summer’s day in Denmark. The tray in the ‘Sammen’ series has two important functions, in addition, of course, to being an indispensable serving tray. It can be placed on the L202 footstool, transforming it into a charming little table. And it can also be used as a small table between two lounge or two dining chairs.

Thomas Alken (b. 1970) graduated as a furniture and industrial designer from Design School Kolding in 1997. He has been involved in a wide range of design projects, from luxury furniture and ketchup bottles to a lounge at Copenhagen Airport, because it is the user situation that fascinates him. In his view, furniture must always be seen in a larger context. And with the ‘Sammen’ (Together) series, he has made sure that the furniture harmonises with the traditions of FDB Møbler as well as Danish gardens.

CARE INSTRUCTIONS

We always recommend that garden furniture is carefully looked after and maintained. In Denmark, humidity levels and large temperature fluctuations can cause wood to crack and warp. This means that mould, for example, is more likely to attack the wood. So, there are many good reasons why you should maintain your wooden garden furniture. The wood will retain its beautiful colour rather than becoming grey and dreary to look at. The garden furniture will be protected against degradation from the weather, wind and sun, and will therefore last longer. With proper treatment, teak garden furniture can last for many years.

Teak contains a lot of natural oils and minerals, so teak furniture can to some extent be left untreated. Over time, the wood will acquire a silver-grey surface, as the rain and sun wash and dry out the top oil layer which is naturally found in the wood. However, to keep the wood healthy, it is a good idea to oil your furniture at least once a year. If you wish to retain the silver-grey finish, use natural oil without colour pigments.

Wooden garden furniture should be washed often to remove dust and dirt to prevent blotching etc. on the surface. If you want to retain the beautiful golden hue of new teak, it should be treated with oil one to three times a year like all other wood types, and with a teak oil containing colour pigments. Before bringing wooden garden furniture inside for the winter, it is important to clean it thoroughly to prevent rot and mould from developing. Retighten the bolts and screws if necessary. It is a good idea to end the season by oiling or painting the furniture. Wood is a living material, and therefore benefits from being stored in a shed, so it is not exposed to moisture during the winter. Wooden garden furniture should not be in direct contact with the ground, as the legs will absorb moisture. If necessary, place tiles under the legs, or make sure to wrap the tarpaulin under the legs of both chairs and tables. Wooden garden furniture does not benefit from being stored in a warm room during the winter, as the wood can dry out completely. This can cause large cracks, and the wood may shrink. When the time comes to take your garden furniture back out into the garden again, it is important that you tighten the screws, bolts and brackets which might have become loose during the winter.



FDB Møbler is manufactured using only FSC-certified wood. FSC certification ensures that no more trees are felled than the forest can reproduce. At the same time, the FSC label guarantees that forest animals and plants are protected, and that the forest workers receive training, safety equipment and a reasonable pay. When you, the consumer, choose FSC, you are helping to protect the natural environment and ensure proper social conditions in the forests where the wood is sourced. In choosing products made with FSC wood, you are supporting forest owners who have chosen to manage their forests in a way that respects the people who work there and the fauna for which the forest is their habitat. For further information, visit www.fsc.dk.



MØBLER

- A PHILOSOPHY -

*“You ought to feel at home
in a piece of furniture”*

Quote: Thomas Alken

Lubricate all moving parts with a neutral oil (for example sewing machine oil). Wash the garden furniture thoroughly. If the furniture was oiled or painted before being put away for the winter, it should now be ready for use. If not, it is a good idea to do so before starting to use the furniture again.

Cleaning

Garden furniture should be cleaned to remove any algae and dirt. It is important to make sure that the furniture is completely clean before it is oiled. Remove dirt, old oil, mould and algae using a stiff brush and plenty of water. Perhaps add a little wood cleaner to the water. However, remember to rinse the furniture thoroughly after washing. Different types of wood cleaner are available, for example wood cleaner for teak, which cleans the wood without removing the natural oils in the wood. Buy the products that are the most suitable for the garden furniture. If the wood is very worn or damaged, it can be deep-cleaned by means of a two-stage cleaning process: First, wash the wood thoroughly, and then neutralise the cleaning to reveal the wood's natural glow and appearance. It is important that the garden furniture dries properly before proceeding to the next step.

Sanding

Often the wood will rise after being soaked with water and cleaner, so all the surfaces need to be sanded. First, use a coarse sandpaper (e.g. 100-120 grit), and then sand with a fine sandpaper (e.g. 200-300 grit). It is important that you always sand with the grain, i.e. lengthwise. Both oiled and painted garden furniture must be sanded. This is necessary to create a fine, smooth surface before treating with oil, or to ensure that the paint adheres to the wood. If the furniture has marks or discolorations which have not been properly treated, or if the furniture has not been stored correctly, such marks and discolorations can often be removed by sanding. Any sanding dust should be removed before the next step.

Oiling/painting

Oiling/painting should be done in a relatively warm place (10-25°C), but not inside so you avoid inhaling oil fumes. Protect the wood with fungicidal oil or paint that will prevent mould and algae growth. If the garden furniture is going to be painted, the best result is achieved by first applying a layer of primer, which should always be allowed to dry until the following day. If the garden furniture is going to be oiled, it is a good idea to use a pigmented oil, which protects the wood against the sun's harmful UV rays. Evenly apply the wood oil or paint using a brush. Take care to saturate the end grain with oil/paint. If necessary, wipe off any small pools of surplus oil on horizontal surfaces with a cloth. These form when the wood is saturated with oil. The garden furniture must have at least two coats of oil/paint to ensure a satisfactory finish. Once the garden furniture has been treated, it should be left for a few days until the

oil/paint is completely dry and can withstand the rain, sun and wind outside. The better the quality of the oil/paint, the better the result. Oil or paint can be purchased from paint shops, builders' merchants and DIY stores. Here, it is also possible to obtain professional advice on which type of oil/paint to use.

Please note!

IT IS IMPORTANT THAT GARDEN FURNITURE STANDS ON A FLAT SURFACE SO THAT ALL THE LEGS ARE IN CONTACT WITH THE GROUND.



FDB Møbler is manufactured using only FSC-certified wood. FSC certification ensures that no more trees are felled than the forest can reproduce. At the same time, the FSC label guarantees that forest animals and plants are protected, and that the forest workers receive training, safety equipment and a reasonable pay. When you, the consumer, choose FSC, you are helping to protect the natural environment and ensure proper social conditions in the forests where the wood is sourced. In choosing products made with FSC wood, you are supporting forest owners who have chosen to manage their forests in a way that respects the people who work there and the fauna for which the forest is their habitat. For further information, visit www.fsc.dk.



MØBLER

- A PHILOSOPHY -

*“You ought to feel at home
in a piece of furniture”*

Quote: Thomas Alken

Dear Customer

FDB Møbler was founded out of a desire to create furniture that makes room for people – a philosophy which has been shaped in oak and beech and woven into seats since 1942. New generations of designers have joined the team since then, but the fundamental mission remains the same: To produce beautiful, functional pieces of furniture made to high standards of craftsmanship that make room for everyday life in living rooms, kitchens and children’s bedrooms. And which can withstand wear and tear, year in and year out. FDB Møbler wrote itself into the annals of Danish design history long ago with classics that

have been passed down for generations. So even if your furniture is brand new, it is already an heirloom, because it is imbued with all the values that we were born with, and which are still honoured to this day when we produce our classics, relaunch furniture from our design archives, or introduce brand-new designs. We hope you will be happy with your new purchase, and that it will enhance your quality of life, as this has been the intention ever since our first pieces of furniture emerged from the drawing board.

• M10 • Sammen – Bench 3. Pers

Designer Thomas Alken

PRODUCT INFORMATION

The bench without back and armrests can be used with the dining table, but also for other purposes. You can lie down and relax on it, use it as a seat in a corner of the garden or simply as a surface on which to place things. The bench matches the other pieces of furniture in the ‘Sammen’ series, such as the dining table, lounge chair and the footstool, yet still stands out on account of its minimalist look and clean lines.

Thomas Alken (b. 1970) graduated as a furniture and industrial designer from Design School Kolding in 1997. He has been involved in a wide range of design projects, from luxury furniture and ketchup bottles to a lounge at Copenhagen Airport, because it is the user situation that fascinates him. In his view, furniture must always be seen in a larger context. And with the ‘Sammen’ (Together) series, he has made sure that the furniture harmonises with the traditions of FDB Møbler as well as Danish gardens.

CARE INSTRUCTIONS

We always recommend that garden furniture is carefully looked after and maintained. In Denmark, humidity levels and large temperature fluctuations can cause wood to crack and warp. This means that mould, for example, is more likely to attack the wood. So, there are many good reasons why you should maintain your wooden garden furniture. The wood will retain its beautiful colour rather than becoming grey and dreary to look at. The garden furniture will be protected against degradation from the weather, wind and sun, and will therefore last longer. With proper treatment, teak garden furniture can last for many years.

Teak contains a lot of natural oils and minerals, so teak furniture can to some extent be left untreated. Over time, the wood will acquire a silver-grey surface, as the rain and sun wash and dry out the top oil layer which is naturally found in the wood. However, to keep the wood healthy, it is a good idea to oil your furniture at least once a year. If you wish to retain the silver-grey finish, use natural oil without colour pigments.

Wooden garden furniture should be washed often to remove dust and dirt to prevent blotching etc. on the surface. If you want to retain the beautiful golden hue of new teak, it should be treated with oil one to three times a year like all other wood types, and with a teak oil containing colour pigments. Before bringing wooden garden furniture inside for the winter, it is important to clean it thoroughly to prevent rot and mould from developing. Retighten the bolts and screws if necessary. It is a good idea to end the season by oiling or painting the furniture. Wood is a living material, and therefore benefits from being stored in a shed, so it is not exposed to moisture during the winter. Wooden garden furniture should not be in direct contact with the ground, as the legs will absorb moisture. If necessary, place tiles under the legs, or make sure to wrap the tarpaulin under the legs of both chairs and tables. Wooden garden furniture does not benefit from being stored in a warm room during the winter, as the wood can dry out completely. This can cause large cracks, and the wood may shrink. When the time comes to take your garden furniture back out into the garden again, it is important that you tighten the screws, bolts and brackets which might have become loose during the winter.



FDB Møbler is manufactured using only FSC-certified wood. FSC certification ensures that no more trees are felled than the forest can reproduce. At the same time, the FSC label guarantees that forest animals and plants are protected, and that the forest workers receive training, safety equipment and a reasonable pay. When you, the consumer, choose FSC, you are helping to protect the natural environment and ensure proper social conditions in the forests where the wood is sourced. In choosing products made with FSC wood, you are supporting forest owners who have chosen to manage their forests in a way that respects the people who work there and the fauna for which the forest is their habitat. For further information, visit www.fsc.dk.



MØBLER

- A PHILOSOPHY -

Lubricate all moving parts with a neutral oil (for example sewing machine oil). Wash the garden furniture thoroughly. If the furniture was oiled or painted before being put away for the winter, it should now be ready for use. If not, it is a good idea to do so before starting to use the furniture again.

Cleaning

Garden furniture should be cleaned to remove any algae and dirt. It is important to make sure that the furniture is completely clean before it is oiled. Remove dirt, old oil, mould and algae using a stiff brush and plenty of water. Perhaps add a little wood cleaner to the water. However, remember to rinse the furniture thoroughly after washing. Different types of wood cleaner are available, for example wood cleaner for teak, which cleans the wood without removing the natural oils in the wood. Buy the products that are the most suitable for the garden furniture. If the wood is very worn or damaged, it can be deep-cleaned by means of a two-stage cleaning process: First, wash the wood thoroughly, and then neutralise the cleaning to reveal the wood's natural glow and appearance. It is important that the garden furniture dries properly before proceeding to the next step.

Sanding

Often the wood will rise after being soaked with water and cleaner, so all the surfaces need to be sanded. First, use a coarse sandpaper (e.g. 100-120 grit), and then sand with a fine sandpaper (e.g. 200-300 grit). It is important that you always sand with the grain, i.e. lengthwise. Both oiled and painted garden furniture must be sanded. This is necessary to create a fine, smooth surface before treating with oil, or to ensure that the paint adheres to the wood. If the furniture has marks or discolorations which have not been properly treated, or if the furniture has not been stored correctly, such marks and discolorations can often be removed by sanding. Any sanding dust should be removed before the next step.

Oiling/painting

Oiling/painting should be done in a relatively warm place (10-25°C), but not inside so you avoid inhaling oil fumes. Protect the wood with fungicidal oil or paint that will prevent mould and algae growth. If the garden furniture is going to be painted, the best result is achieved by first applying a layer of primer, which should always be allowed to dry until the following day. If the garden furniture is going to be oiled, it is a good idea to use a pigmented oil, which protects the wood against the sun's harmful UV rays. Evenly apply the wood oil or paint using a brush. Take care to saturate the end grain with oil/paint. If necessary, wipe off any small pools of surplus oil on horizontal surfaces with a cloth. These form when the wood is saturated with oil. The garden furniture must have at least two coats of oil/paint to ensure a satisfactory finish. Once the garden furniture has been treated, it should be left for a few days until the

*“You ought to feel at home
in a piece of furniture”*

Quote: Thomas Alken

oil/paint is completely dry and can withstand the rain, sun and wind outside. The better the quality of the oil/paint, the better the result. Oil or paint can be purchased from paint shops, builders' merchants and DIY stores. Here, it is also possible to obtain professional advice on which type of oil/paint to use.

Please note!

IT IS IMPORTANT THAT GARDEN FURNITURE STANDS ON A FLAT SURFACE SO THAT ALL THE LEGS ARE IN CONTACT WITH THE GROUND.

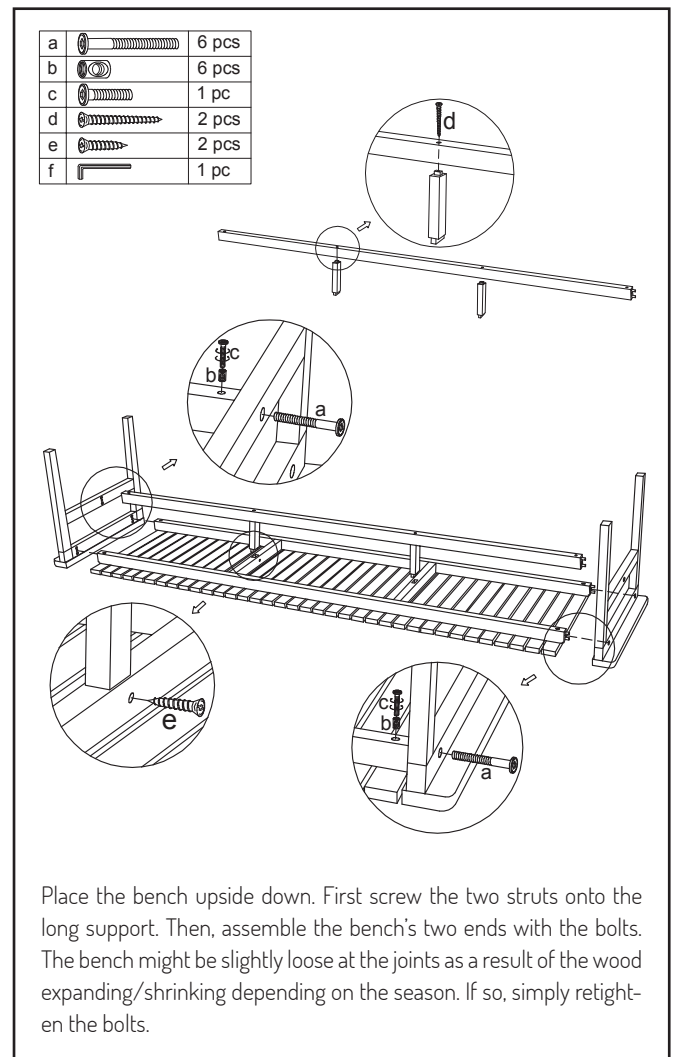

FDB Møbler is manufactured using only FSC-certified wood. FSC certification ensures that no more trees are felled than the forest can reproduce. At the same time, the FSC label guarantees that forest animals and plants are protected, and that the forest workers receive training, safety equipment and a reasonable pay. When you, the consumer, choose FSC, you are helping to protect the natural environment and ensure proper social conditions in the forests where the wood is sourced. In choosing products made with FSC wood, you are supporting forest owners who have chosen to manage their forests in a way that respects the people who work there and the fauna for which the forest is their habitat. For further information, visit www.fsc.dk.



MØBLER

- A PHILOSOPHY -

*“You ought to feel at home
in a piece of furniture”*

Quote: Thomas Alken

Dear Customer

FDB Møbler was founded out of a desire to create furniture that makes room for people – a philosophy which has been shaped in oak and beech and woven into seats since 1942. New generations of designers have joined the team since then, but the fundamental mission remains the same: To produce beautiful, functional pieces of furniture made to high standards of craftsmanship that make room for everyday life in living rooms, kitchens and children’s bedrooms. And which can withstand wear and tear, year in and year out. FDB Møbler wrote itself into the annals of Danish design history long ago with classics that

have been passed down for generations. So even if your furniture is brand new, it is already an heirloom, because it is imbued with all the values that we were born with, and which are still honoured to this day when we produce our classics, relaunch furniture from our design archives, or introduce brand-new designs. We hope you will be happy with your new purchase, and that it will enhance your quality of life, as this has been the intention ever since our first pieces of furniture emerged from the drawing board.

• M11 • Sammen – Bench 3. Pers

Designer Thomas Alken

PRODUCT INFORMATION

The garden bench is the ideal solution when you need extra seating at the dining table, and is especially suitable for children when eating outside in the summer. The bench can also be taken to a corner of the garden, which can then be enjoyed from a completely new angle. The bench is born of FDB Møbler’s design tradition, and is made of natural oiled teak with numerous details that highlight the quality of both its craftsmanship and design. It matches the large C201b dining table and, of course, the two chairs in the series.

Thomas Alken (b. 1970) graduated as a furniture and industrial designer from Design School Kolding in 1997. He has been involved in a wide range of design projects, from luxury furniture and ketchup bottles to a lounge at Copenhagen Airport, because it is the user situation that fascinates him. In his view, furniture must always be seen in a larger context. And with the ‘Sammen’ (Together) series, he has made sure that the furniture harmonises with the traditions of FDB Møbler as well as Danish gardens.

CARE INSTRUCTIONS

We always recommend that garden furniture is carefully looked after and maintained. In Denmark, humidity levels and large temperature fluctuations can cause wood to crack and warp. This means that mould, for example, is more likely to attack the wood. So, there are many good reasons why you should maintain your wooden garden furniture. The wood will retain its beautiful colour rather than becoming grey and dreary to look at. The garden furniture will be protected against degradation from the weather, wind and sun, and will therefore last longer. With proper treatment, teak garden furniture can last for many years.

Teak contains a lot of natural oils and minerals, so teak furniture can to some extent be left untreated. Over time, the wood will acquire a silver-grey surface, as the rain and sun wash and dry out the top oil layer which is naturally found in the wood. However, to keep the wood healthy, it is a good idea to oil your furniture at least once a year. If you wish to retain the silver-grey finish, use natural oil without colour pigments.

Wooden garden furniture should be washed often to remove dust and dirt to prevent blotching etc. on the surface. If you want to retain the beautiful golden hue of new teak, it should be treated with oil one to three times a year like all other wood types, and with a teak oil containing colour pigments. Before bringing wooden garden furniture inside for the winter, it is important to clean it thoroughly to prevent rot and mould from developing. Retighten the bolts and screws if necessary. It is a good idea to end the season by oiling or painting the furniture. Wood is a living material, and therefore benefits from being stored in a shed, so it is not exposed to moisture during the winter. Wooden garden furniture should not be in direct contact with the ground, as the legs will absorb moisture. If necessary, place tiles under the legs, or make sure to wrap the tarpaulin under the legs of both chairs and tables. Wooden garden furniture does not benefit from being stored in a warm room during the winter, as the wood can dry out completely. This can cause large cracks, and the wood may shrink. When the time comes to take your garden furniture back out into the garden again, it is important that you tighten the screws, bolts and brackets which might have become loose during the winter.



FDB Møbler is manufactured using only FSC-certified wood. FSC certification ensures that no more trees are felled than the forest can reproduce. At the same time, the FSC label guarantees that forest animals and plants are protected, and that the forest workers receive training, safety equipment and a reasonable pay. When you, the consumer, choose FSC, you are helping to protect the natural environment and ensure proper social conditions in the forests where the wood is sourced. In choosing products made with FSC wood, you are supporting forest owners who have chosen to manage their forests in a way that respects the people who work there and the fauna for which the forest is their habitat. For further information, visit www.fsc.dk.



MØBLER

- A PHILOSOPHY -

*“You ought to feel at home
in a piece of furniture”*

Quote: Thomas Alken

Lubricate all moving parts with a neutral oil (for example sewing machine oil). Wash the garden furniture thoroughly. If the furniture was oiled or painted before being put away for the winter, it should now be ready for use. If not, it is a good idea to do so before starting to use the furniture again.

Cleaning

Garden furniture should be cleaned to remove any algae and dirt. It is important to make sure that the furniture is completely clean before it is oiled. Remove dirt, old oil, mould and algae using a stiff brush and plenty of water. Perhaps add a little wood cleaner to the water. However, remember to rinse the furniture thoroughly after washing. Different types of wood cleaner are available, for example wood cleaner for teak, which cleans the wood without removing the natural oils in the wood. Buy the products that are the most suitable for the garden furniture. If the wood is very worn or damaged, it can be deep-cleaned by means of a two-stage cleaning process: First, wash the wood thoroughly, and then neutralise the cleaning to reveal the wood's natural glow and appearance. It is important that the garden furniture dries properly before proceeding to the next step.

Sanding

Often the wood will rise after being soaked with water and cleaner, so all the surfaces need to be sanded. First, use a coarse sandpaper (e.g. 100-120 grit), and then sand with a fine sandpaper (e.g. 200-300 grit). It is important that you always sand with the grain, i.e. lengthwise. Both oiled and painted garden furniture must be sanded. This is necessary to create a fine, smooth surface before treating with oil, or to ensure that the paint adheres to the wood. If the furniture has marks or discolorations which have not been properly treated, or if the furniture has not been stored correctly, such marks and discolorations can often be removed by sanding. Any sanding dust should be removed before the next step.

Oiling/painting

Oiling/painting should be done in a relatively warm place (10-25°C), but not inside so you avoid inhaling oil fumes. Protect the wood with fungicidal oil or paint that will prevent mould and algae growth. If the garden furniture is going to be painted, the best result is achieved by first applying a layer of primer, which should always be allowed to dry until the following day. If the garden furniture is going to be oiled, it is a good idea to use a pigmented oil, which protects the wood against the sun's harmful UV rays. Evenly apply the wood oil or paint using a brush. Take care to saturate the end grain with oil/paint. If necessary, wipe off any small pools of surplus oil on horizontal surfaces with a cloth. These form when the wood is saturated with oil. The garden furniture must have at least two coats of oil/paint to ensure a satisfactory finish. Once the garden furniture has been treated, it should be left for a few days until the

oil/paint is completely dry and can withstand the rain, sun and wind outside. The better the quality of the oil/paint, the better the result. Oil or paint can be purchased from paint shops, builders' merchants and DIY stores. Here, it is also possible to obtain professional advice on which type of oil/paint to use.

Please note!

IT IS IMPORTANT THAT GARDEN FURNITURE STANDS ON A FLAT SURFACE SO THAT ALL THE LEGS ARE IN CONTACT WITH THE GROUND.



FDB Møbler is manufactured using only FSC-certified wood. FSC certification ensures that no more trees are felled than the forest can reproduce. At the same time, the FSC label guarantees that forest animals and plants are protected, and that the forest workers receive training, safety equipment and a reasonable pay. When you, the consumer, choose FSC, you are helping to protect the natural environment and ensure proper social conditions in the forests where the wood is sourced. In choosing products made with FSC wood, you are supporting forest owners who have chosen to manage their forests in a way that respects the people who work there and the fauna for which the forest is their habitat. For further information, visit www.fsc.dk.



MØBLER

- A PHILOSOPHY -

*“You ought to feel at home
in a piece of furniture”*

Quote: Thomas Alken

Dear Customer

FDB Møbler was founded out of a desire to create furniture that makes room for people – a philosophy which has been shaped in oak and beech and woven into seats since 1942. New generations of designers have joined the team since then, but the fundamental mission remains the same: To produce beautiful, functional pieces of furniture made to high standards of craftsmanship that make room for everyday life in living rooms, kitchens and children’s bedrooms. And which can withstand wear and tear, year in and year out. FDB Møbler wrote itself into the annals of Danish design history long ago with classics that

have been passed down for generations. So even if your furniture is brand new, it is already an heirloom, because it is imbued with all the values that we were born with, and which are still honoured to this day when we produce our classics, relaunch furniture from our design archives, or introduce brand-new designs. We hope you will be happy with your new purchase, and that it will enhance your quality of life, as this has been the intention ever since our first pieces of furniture emerged from the drawing board.

• M12 • Sammen – Bench 2. Pers

Designer Thomas Alken

PRODUCT INFORMATION

The garden bench is the ideal solution when you need extra seating at the dining table, and is especially suitable for children when eating outside in the summer. The bench can also be taken to a corner of the garden, which can then be enjoyed from a completely new angle. The bench is born of FDB Møbler’s design tradition, and is made of natural oiled teak with numerous details that highlight the quality of both its craftsmanship and design. It matches the large C201b dining table and, of course, the two chairs in the series.

Thomas Alken (b. 1970) graduated as a furniture and industrial designer from Design School Kolding in 1997. He has been involved in a wide range of design projects, from luxury furniture and ketchup bottles to a lounge at Copenhagen Airport, because it is the user situation that fascinates him. In his view, furniture must always be seen in a larger context. And with the ‘Sammen’ (Together) series, he has made sure that the furniture harmonises with the traditions of FDB Møbler as well as Danish gardens.

CARE INSTRUCTIONS

We always recommend that garden furniture is carefully looked after and maintained. In Denmark, humidity levels and large temperature fluctuations can cause wood to crack and warp. This means that mould, for example, is more likely to attack the wood. So, there are many good reasons why you should maintain your wooden garden furniture. The wood will retain its beautiful colour rather than becoming grey and dreary to look at. The garden furniture will be protected against degradation from the weather, wind and sun, and will therefore last longer. With proper treatment, teak garden furniture can last for many years.

Teak contains a lot of natural oils and minerals, so teak furniture can to some extent be left untreated. Over time, the wood will acquire a silver-grey surface, as the rain and sun wash and dry out the top oil layer which is naturally found in the wood. However, to keep the wood healthy, it is a good idea to oil your furniture at least once a year. If you wish to retain the silver-grey finish, use natural oil without colour pigments.

Wooden garden furniture should be washed often to remove dust and dirt to prevent blotching etc. on the surface. If you want to retain the beautiful golden hue of new teak, it should be treated with oil one to three times a year like all other wood types, and with a teak oil containing colour pigments. Before bringing wooden garden furniture inside for the winter, it is important to clean it thoroughly to prevent rot and mould from developing. Retighten the bolts and screws if necessary. It is a good idea to end the season by oiling or painting the furniture. Wood is a living material, and therefore benefits from being stored in a shed, so it is not exposed to moisture during the winter. Wooden garden furniture should not be in direct contact with the ground, as the legs will absorb moisture. If necessary, place tiles under the legs, or make sure to wrap the tarpaulin under the legs of both chairs and tables. Wooden garden furniture does not benefit from being stored in a warm room during the winter, as the wood can dry out completely. This can cause large cracks, and the wood may shrink. When the time comes to take your garden furniture back out into the garden again, it is important that you tighten the screws, bolts and brackets which might have become loose during the winter.



FDB Møbler is manufactured using only FSC-certified wood. FSC certification ensures that no more trees are felled than the forest can reproduce. At the same time, the FSC label guarantees that forest animals and plants are protected, and that the forest workers receive training, safety equipment and a reasonable pay. When you, the consumer, choose FSC, you are helping to protect the natural environment and ensure proper social conditions in the forests where the wood is sourced. In choosing products made with FSC wood, you are supporting forest owners who have chosen to manage their forests in a way that respects the people who work there and the fauna for which the forest is their habitat. For further information, visit www.fsc.dk.



MØBLER

- A PHILOSOPHY -

*“You ought to feel at home
in a piece of furniture”*

Quote: Thomas Alken

Lubricate all moving parts with a neutral oil (for example sewing machine oil). Wash the garden furniture thoroughly. If the furniture was oiled or painted before being put away for the winter, it should now be ready for use. If not, it is a good idea to do so before starting to use the furniture again.

Cleaning

Garden furniture should be cleaned to remove any algae and dirt. It is important to make sure that the furniture is completely clean before it is oiled. Remove dirt, old oil, mould and algae using a stiff brush and plenty of water. Perhaps add a little wood cleaner to the water. However, remember to rinse the furniture thoroughly after washing. Different types of wood cleaner are available, for example wood cleaner for teak, which cleans the wood without removing the natural oils in the wood. Buy the products that are the most suitable for the garden furniture. If the wood is very worn or damaged, it can be deep-cleaned by means of a two-stage cleaning process: First, wash the wood thoroughly, and then neutralise the cleaning to reveal the wood's natural glow and appearance. It is important that the garden furniture dries properly before proceeding to the next step.

Sanding

Often the wood will rise after being soaked with water and cleaner, so all the surfaces need to be sanded. First, use a coarse sandpaper (e.g. 100-120 grit), and then sand with a fine sandpaper (e.g. 200-300 grit). It is important that you always sand with the grain, i.e. lengthwise. Both oiled and painted garden furniture must be sanded. This is necessary to create a fine, smooth surface before treating with oil, or to ensure that the paint adheres to the wood. If the furniture has marks or discolorations which have not been properly treated, or if the furniture has not been stored correctly, such marks and discolorations can often be removed by sanding. Any sanding dust should be removed before the next step.

Oiling/painting

Oiling/painting should be done in a relatively warm place (10-25°C), but not inside so you avoid inhaling oil fumes. Protect the wood with fungicidal oil or paint that will prevent mould and algae growth. If the garden furniture is going to be painted, the best result is achieved by first applying a layer of primer, which should always be allowed to dry until the following day. If the garden furniture is going to be oiled, it is a good idea to use a pigmented oil, which protects the wood against the sun's harmful UV rays. Evenly apply the wood oil or paint using a brush. Take care to saturate the end grain with oil/paint. If necessary, wipe off any small pools of surplus oil on horizontal surfaces with a cloth. These form when the wood is saturated with oil. The garden furniture must have at least two coats of oil/paint to ensure a satisfactory finish. Once the garden furniture has been treated, it should be left for a few days until the

oil/paint is completely dry and can withstand the rain, sun and wind outside. The better the quality of the oil/paint, the better the result. Oil or paint can be purchased from paint shops, builders' merchants and DIY stores. Here, it is also possible to obtain professional advice on which type of oil/paint to use.

Please note!

IT IS IMPORTANT THAT GARDEN FURNITURE STANDS ON A FLAT SURFACE SO THAT ALL THE LEGS ARE IN CONTACT WITH THE GROUND.



FDB Møbler is manufactured using only FSC-certified wood. FSC certification ensures that no more trees are felled than the forest can reproduce. At the same time, the FSC label guarantees that forest animals and plants are protected, and that the forest workers receive training, safety equipment and a reasonable pay. When you, the consumer, choose FSC, you are helping to protect the natural environment and ensure proper social conditions in the forests where the wood is sourced. In choosing products made with FSC wood, you are supporting forest owners who have chosen to manage their forests in a way that respects the people who work there and the fauna for which the forest is their habitat. For further information, visit www.fsc.dk.



MØBLER

- A PHILOSOPHY -

*“You ought to feel at home
in a piece of furniture”*

Quote: Thomas Alken

Dear Customer

FDB Møbler was founded out of a desire to create furniture that makes room for people – a philosophy which has been shaped in oak and beech and woven into seats since 1942. New generations of designers have joined the team since then, but the fundamental mission remains the same: To produce beautiful, functional pieces of furniture made to high standards of craftsmanship that make room for everyday life in living rooms, kitchens and children’s bedrooms. And which can withstand wear and tear, year in and year out. FDB Møbler wrote itself into the annals of Danish design history long ago with classics that

have been passed down for generations. So even if your furniture is brand new, it is already an heirloom, because it is imbued with all the values that we were born with, and which are still honoured to this day when we produce our classics, relaunch furniture from our design archives, or introduce brand-new designs. We hope you will be happy with your new purchase, and that it will enhance your quality of life, as this has been the intention ever since our first pieces of furniture emerged from the drawing board.

• M14 • Sammen – Bench 2. Pers

Designer Thomas Alken

PRODUCT INFORMATION

The garden bench is the ideal solution when you need extra seating at the dining table, and is especially suitable for children when eating outside in the summer. The bench can also be taken to a corner of the garden, which can then be enjoyed from a completely new angle. The bench is born of FDB Møbler’s design tradition, and is made of natural oiled teak with numerous details that highlight the quality of both its craftsmanship and design. It matches the large C201b dining table and, of course, the two chairs in the series.

Thomas Alken (b. 1970) graduated as a furniture and industrial designer from Design School Kolding in 1997. He has been involved in a wide range of design projects, from luxury furniture and ketchup bottles to a lounge at Copenhagen Airport, because it is the user situation that fascinates him. In his view, furniture must always be seen in a larger context. And with the ‘Sammen’ (Together) series, he has made sure that the furniture harmonises with the traditions of FDB Møbler as well as Danish gardens.

CARE INSTRUCTIONS

We always recommend that garden furniture is carefully looked after and maintained. In Denmark, humidity levels and large temperature fluctuations can cause wood to crack and warp. This means that mould, for example, is more likely to attack the wood. So, there are many good reasons why you should maintain your wooden garden furniture. The wood will retain its beautiful colour rather than becoming grey and dreary to look at. The garden furniture will be protected against degradation from the weather, wind and sun, and will therefore last longer. With proper treatment, teak garden furniture can last for many years.

Teak contains a lot of natural oils and minerals, so teak furniture can to some extent be left untreated. Over time, the wood will acquire a silver-grey surface, as the rain and sun wash and dry out the top oil layer which is naturally found in the wood. However, to keep the wood healthy, it is a good idea to oil your furniture at least once a year. If you wish to retain the silver-grey finish, use natural oil without colour pigments.

Wooden garden furniture should be washed often to remove dust and dirt to prevent blotching etc. on the surface. If you want to retain the beautiful golden hue of new teak, it should be treated with oil one to three times a year like all other wood types, and with a teak oil containing colour pigments. Before bringing wooden garden furniture inside for the winter, it is important to clean it thoroughly to prevent rot and mould from developing. Retighten the bolts and screws if necessary. It is a good idea to end the season by oiling or painting the furniture. Wood is a living material, and therefore benefits from being stored in a shed, so it is not exposed to moisture during the winter. Wooden garden furniture should not be in direct contact with the ground, as the legs will absorb moisture. If necessary, place tiles under the legs, or make sure to wrap the tarpaulin under the legs of both chairs and tables. Wooden garden furniture does not benefit from being stored in a warm room during the winter, as the wood can dry out completely. This can cause large cracks, and the wood may shrink. When the time comes to take your garden furniture back out into the garden again, it is important that you tighten the screws, bolts and brackets which might have become loose during the winter.



FDB Møbler is manufactured using only FSC-certified wood. FSC certification ensures that no more trees are felled than the forest can reproduce. At the same time, the FSC label guarantees that forest animals and plants are protected, and that the forest workers receive training, safety equipment and a reasonable pay. When you, the consumer, choose FSC, you are helping to protect the natural environment and ensure proper social conditions in the forests where the wood is sourced. In choosing products made with FSC wood, you are supporting forest owners who have chosen to manage their forests in a way that respects the people who work there and the fauna for which the forest is their habitat. For further information, visit www.fsc.dk.



MØBLER

- A PHILOSOPHY -

*“You ought to feel at home
in a piece of furniture”*

Quote: Thomas Alken

Lubricate all moving parts with a neutral oil (for example sewing machine oil). Wash the garden furniture thoroughly. If the furniture was oiled or painted before being put away for the winter, it should now be ready for use. If not, it is a good idea to do so before starting to use the furniture again.

Cleaning

Garden furniture should be cleaned to remove any algae and dirt. It is important to make sure that the furniture is completely clean before it is oiled. Remove dirt, old oil, mould and algae using a stiff brush and plenty of water. Perhaps add a little wood cleaner to the water. However, remember to rinse the furniture thoroughly after washing. Different types of wood cleaner are available, for example wood cleaner for teak, which cleans the wood without removing the natural oils in the wood. Buy the products that are the most suitable for the garden furniture. If the wood is very worn or damaged, it can be deep-cleaned by means of a two-stage cleaning process: First, wash the wood thoroughly, and then neutralise the cleaning to reveal the wood's natural glow and appearance. It is important that the garden furniture dries properly before proceeding to the next step.

Sanding

Often the wood will rise after being soaked with water and cleaner, so all the surfaces need to be sanded. First, use a coarse sandpaper (e.g. 100-120 grit), and then sand with a fine sandpaper (e.g. 200-300 grit). It is important that you always sand with the grain, i.e. lengthwise. Both oiled and painted garden furniture must be sanded. This is necessary to create a fine, smooth surface before treating with oil, or to ensure that the paint adheres to the wood. If the furniture has marks or discolorations which have not been properly treated, or if the furniture has not been stored correctly, such marks and discolorations can often be removed by sanding. Any sanding dust should be removed before the next step.

Oiling/painting

Oiling/painting should be done in a relatively warm place (10-25°C), but not inside so you avoid inhaling oil fumes. Protect the wood with fungicidal oil or paint that will prevent mould and algae growth. If the garden furniture is going to be painted, the best result is achieved by first applying a layer of primer, which should always be allowed to dry until the following day. If the garden furniture is going to be oiled, it is a good idea to use a pigmented oil, which protects the wood against the sun's harmful UV rays. Evenly apply the wood oil or paint using a brush. Take care to saturate the end grain with oil/paint. If necessary, wipe off any small pools of surplus oil on horizontal surfaces with a cloth. These form when the wood is saturated with oil. The garden furniture must have at least two coats of oil/paint to ensure a satisfactory finish. Once the garden furniture has been treated, it should be left for a few days until the

oil/paint is completely dry and can withstand the rain, sun and wind outside. The better the quality of the oil/paint, the better the result. Oil or paint can be purchased from paint shops, builders' merchants and DIY stores. Here, it is also possible to obtain professional advice on which type of oil/paint to use.

Please note!

IT IS IMPORTANT THAT GARDEN FURNITURE STANDS ON A FLAT SURFACE SO THAT ALL THE LEGS ARE IN CONTACT WITH THE GROUND.

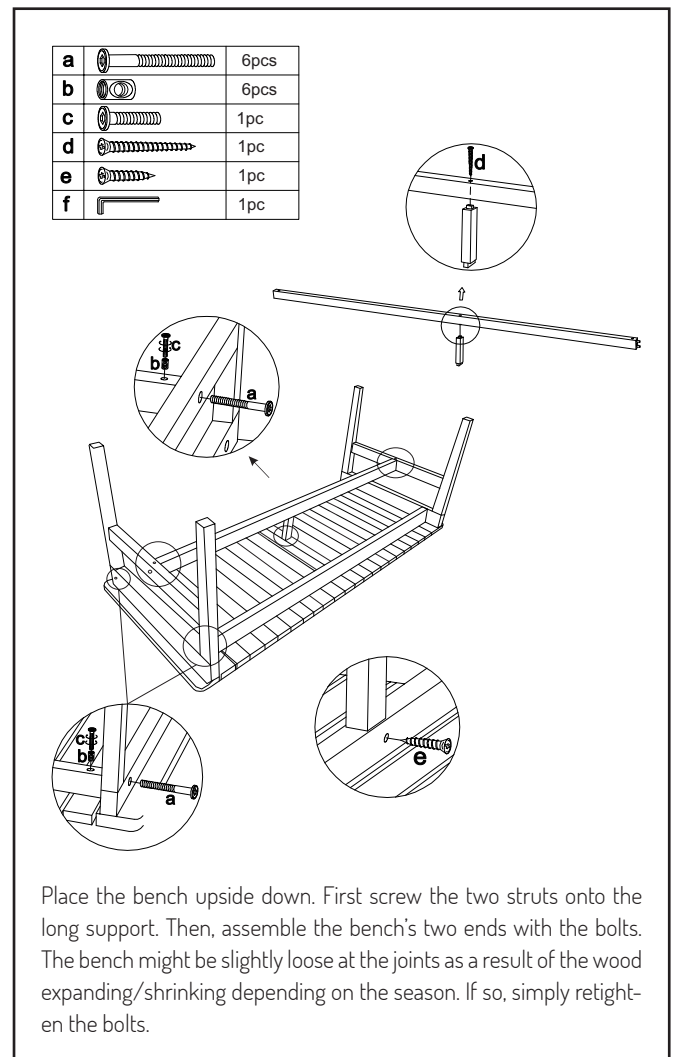

Place the bench upside down. First screw the two struts onto the long support. Then, assemble the bench's two ends with the bolts. The bench might be slightly loose at the joints as a result of the wood expanding/shrinking depending on the season. If so, simply retighten the bolts.



FDB Møbler is manufactured using only FSC-certified wood. FSC certification ensures that no more trees are felled than the forest can reproduce. At the same time, the FSC label guarantees that forest animals and plants are protected, and that the forest workers receive training, safety equipment and a reasonable pay. When you, the consumer, choose FSC, you are helping to protect the natural environment and ensure proper social conditions in the forests where the wood is sourced. In choosing products made with FSC wood, you are supporting forest owners who have chosen to manage their forests in a way that respects the people who work there and the fauna for which the forest is their habitat. For further information, visit www.fsc.dk.